



JRS
FARM PARTS



Let's Win... Together

TRAILER PARTS CATALOG

www.jrsparts.com
www.jrsfarmparts.com





This Catalogue is

COMPLETE TRAILER PARTS SOLUTION for YOU

JRS Farm Parts produced by flagship Eastman group company Eastman Industries Limited in India since 1978. It is engaged in producing quality Trailer parts along with Tractor linkage parts.

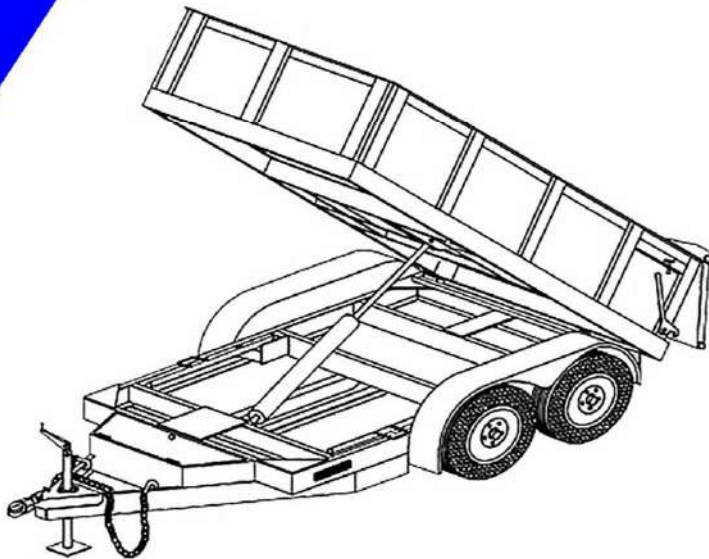
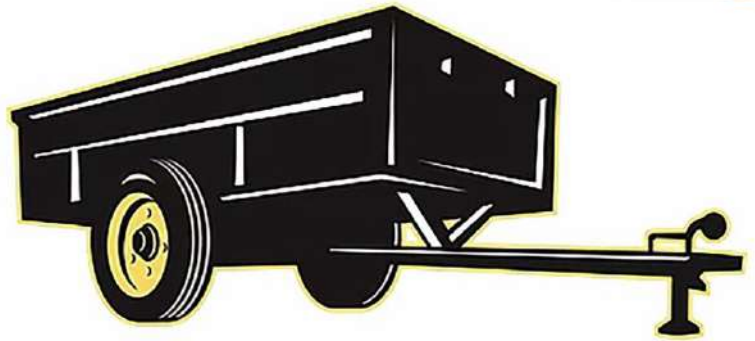

JRS Trailer Parts are according to mainstream market. The product quality and technical specification reached the state standards of United States, European Union, Australia and other Countries. The product exported to 70 countries and regions.

JRS Trailer Parts has always been committed to build company into world leader of Trailer Parts. It is best partner of global transport vehicle producers and operations.

By inheriting our experience we will stick to continuous innovations, research development, take advantage of our competitive manufacturing mode to continuously create more competitive products, help customers at home and abroad to improve efficiency, promote the brand, lower the operating costs and enhance customer competitiveness wise and hardworking Eastman people will work with customers at home and abroad to create new brilliant tomorrow.





SAFE TOWING GUIDE

IMPORTANT INFORMATION ON TOWING

TOWING EQUIPMENT OWNERS: Make sure all operators of your equipment read and understand this information before towing. Save for reference. This will help you properly select, use and maintain your towing equipment. Refer to owner's manuals for your tow vehicle, trailer, and other parts of your towing system. Learn the capabilities and limitations of each part. **GROSS TRAILER WEIGHT** and **TONGUE WEIGHT** are two of the most important items to consider. **THESE WEIGHTS MUST NEVER EXCEED THE LOWEST RATING OF ANY PART OF YOUR TOWING SYSTEM.** **GROSS TRAILER WEIGHT** is the weight of the trailer plus all cargo. Measure **GROSS TRAILER WEIGHT** by putting the fully loaded trailer on a vehicle scale. **TONGUE WEIGHT** is the downward force exerted on the ball by the trailer coupler. Measure **TONGUE WEIGHT** with the fully loaded trailer on a level surface. The coupler must be at its normal towing height. Use a commercial scale or a bathroom scale. Set up the bathroom scale as shown for heavy tongue weights.

YOUR TOWING EQUIPMENT

TRAILER HITCHES, RECEIVERS, AND BALL MOUNTS Select these products by their gross trailer weight and tongue weight ratings. Match the products according to the anticipated use. Use only those products designed for your vehicle.

HITCH BALLS

Select by gross trailer weight rating, mounting platform thickness and hole size, and coupler socket size. Do not mix one class of hitch ball with another class of coupler. Platform must be at least 3/8 inch thick. Hole must not exceed threaded shank diameter by more than 1/16 inch. Use lock washer. Tighten per instructions. When tightened, shank must protrude beyond bottom of nut. Gross trailer weight rating and ball diameter are marked on hitch balls.

TRAILER COUPLERS

The coupler socket should be smooth, clean, and lightly lubricated. Tighten or adjust per coupler manufacturer's instructions. Use proper class type.

SAFETY CHAINS

Connect safety chains properly **EVERY TIME YOU TOW**. Cross chains under coupler. This is done to cradle the trailer tongue in the event the ball and coupler separate. Attach securely to the hitch or tow vehicle so they can't bounce loose. Leave only enough slack to permit full turning. Too much slack may prevent chains from maintaining control if other connections separate. Don't let chains drag on the road to avoid chain degradation.

TRAILER LIGHTS, TURN SIGNALS, ELECTRIC BRAKES, AND BREAK AWAY SWITCH CONNECTIONS

Make these safety-critical connections **EVERY TIME YOU TOW**, no matter how short the trip. Check operation, including electric brake manual control, before getting on the road.

SWAY CONTROLS

Sway controls can lessen the effects of sudden maneuvers, wind gusts, and buffeting caused by other vehicles. We recommend them for trailers with large surface areas, such as travel trailers. Adjustable friction models can help control trailers with low tongue weight. Recommended tongue weight is 10% of gross trailer weight.

OTHER USEFUL EQUIPMENT

AIR SPRINGS, AIR SHOCKS, or HELPER SPRINGS are useful for some hitch applications. A **TRANSMISSION COOLER** may be for heavy towing. Many states require **TOWING MIRRORS** on both sides.

TIRE INFLATION

Check often. Follow tow vehicle and trailer manufacturers' recommendations. Improper tire inflation can cause uncontrollable trailer sway.

CHECK YOUR EQUIPMENT / REPLACE WORN PARTS

Check ball, coupler, chains, retaining pins and clips, and all other connectors **EVERY TIME YOU TOW**. Re-check at fuel and rest stops.

SAFE TOWING TIPS NO PASSENGERS IN TRAILERS!

Never allow people in trailers while towing, under any circumstances.

TRAILER LOADING

Proper loading helps prevent sway. Place heavy object on the floor ahead of the axle. Balance the load side-to-side. Secure it to prevent shifting. Tongue weight should be 10-15 percent of gross weight for most trailers. Too low a percentage of tongue weight can cause sway. **NEVER** load the trailer rear-heavy. **LOAD THE TRAILER HEAVIER IN FRONT.**



DRIVING

The additional weight of a trailer affects acceleration, braking and handling. Allow extra time for passing, stopping, and changing lanes. Severe bumps can damage your towing vehicle, hitch, and trailer. Drive slowly on rough roads. **STOP AND MAKE A THOROUGH**

INSPECTION IF ANY PART OF YOUR TOWING SYSTEM STRIKES THE ROAD. CORRECT ANY PROBLEMS AND REPLACE ANY DAMAGED PARTS BEFORE RESUMING TRAVEL CHECK FOR EXCESSIVE SWAY AND ELIMINATE IT

Excessive sway can lead to loss of control. Sway motion should settle out quickly. Sway tends to increase on a downgrade. Starting slowly, increase speed in gradual steps. If sway occurs, adjust your trailer load and equipment. Repeat until the trailer is stable at highway speed. Do this whenever your trailer loading changes.

IF TRAILER SUDDENLY STARTS TO SWAY

Turbulence from another vehicle, a wind gust, or a downgrade can cause sudden sway. So can a shift of the trailer's load or a trailer tire blowout. **IF THE TRAILER SWAYS, IT IS THE DRIVER'S RESPONSIBILITY TO ASSESS THE SITUATION AND TAKE APPROPRIATE ACTION.** Below are suggestions that may apply, depending on conditions:

DO

- Reduce your speed gradually
- Hold the steering wheel as steady as possible
- If your trailer has electric brakes, apply the trailer brakes alone, without using the tow vehicle's brakes

DON'T

- Don't hit your brake pedal hard unless absolutely necessary. A "jackknife" can result
- Don't try to steer out of the sway condition. Sudden or violent steering can make it worse
- Don't speed up. Sway increases as you go faster
- Don't continue towing a trailer that tends to sway. You may lose control during an emergency maneuver or if the conditions listed above occur

DANGER

DO NOT MODIFY PRODUCT. TOWING VEHICLE MUST BE IN GOOD CONDITION. USE ONLY FOR TRAILER TOWING AND/OR ATTACHMENT OF CEQUENT PERFORMANCE PRODUCTS INC. ACCESSORIES. DO NOT EXTEND ORIGINAL STRUCTURE. DO NOT TOW ONE TRAILER BEHIND ANOTHER, WHICH MAY CAUSE LOSS OF CONTROL. FAILURE TO HEED WARNINGS AND FOLLOW INSTRUCTIONS MAY RESULT IN SERIOUS PERSONAL INJURY OR DEATH, VEHICLE CRASH, AND/OR PROPERTY DAMAGE.

DO NOT OVERLOAD ANY PART OF YOUR TOWING SYSTEM





Let's Win.... Together

TRAILER COUPLER



Trailer Couplers A-Frame



Trailer Couplers Adjustable



Trailer Ball Coupling





Trailer Couplers A-Frame

- Fits A-Frame Trailer tongues and 2" to 2.5/16" balls.
- Passes SAE-684 performance testing as a class 4 coupler.
- Solid forged neck for increased strength and greater corrosion resistance.
- Sleeve-lock latch system for a secure mount.
- Features holes to accept a safety pin or coupler lock.
- Glossy black powder coated Finish.



Code	Mount on Hitch Ball	Capacity
TR703028	2"	7000 Lbs
TR703056	2.5/16"	8000 Lbs

Trailer Couplers Adjustable



- **EASILY ADJUSTABLE** : Designed to mount on to a vertical channel bracket this trailer coupler can easily be adjusting up & down to ensure level towing across your vehicle and trailer.
- **SECURE COUPLING** : The sleeve lock latch mechanism of this trailer tongue coupler fully fits the trailer ball when coupled, providing maximum security and safety for towing.
- **PRECISE FIT** : This trailer coupler can be mounted on a wide variety of heavy-duty trailers and couple to any standard 2", 2.5/16"(inch) diameter trailer ball.
- **CORROSION RESISTANT** : To easily outlet the elements, including rain snow, dirt, road grime and more, this adjustable trailer coupler is finished in a durable black powder coat.
- **HIGH STRENGTH** : Constructed from forged material, this trailer ball coupler has a capacity of 12500 lbs. gross trailer weight.

CODE	MOUNT ON HITCH BALL	CAPACITY
TRAC7000	2"	13000 Lbs
TRAC15000	2.5/16"	15000 Lbs

GO GREEN





Trailer Ball Coupling

Acomplamiento De Bolas

JRS Farm Parts is capable of producing European Couplers with minimum trailers sway. We follow internationally accepted standards for producing Couplers. We have different models in our Coupler portfolio.

Code	A	Capacity	Wear Indicator	D (mm)
TRBC050T1	50	800Kg	Yes	11

 Our Coupler are Easy to attach with Ø50mm Hitch Ball and can take load of the Trailer upto 800Kg.

 It is best to buy suitable Hitch Ball for our Couplers from **JRS** Farm Parts as Hitch Balls are made from high tensile Steel and are properly heat treated.

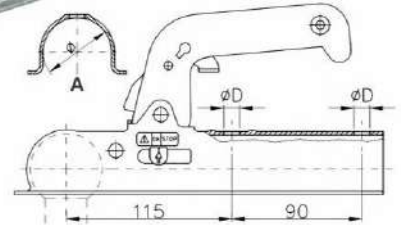

Trailer Ball Coupling

Acomplamiento De Bolas

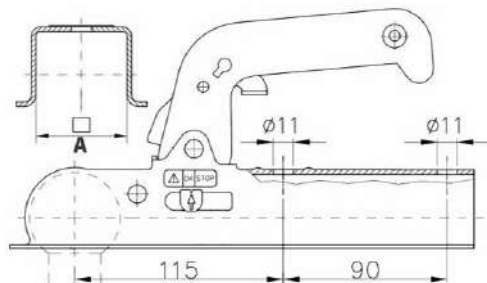

Special Qualities :

- Ball Diameter - 50mm.
- Max. Bearing load S-75Kg.
- Large Handle.
- Opening by Tilling the handle forward.
- Opening by Tilling the handle forward.
- With two screw the old Coupling can be removed and new coupling can be reload.
- Closes Coupling by pressure downward or by support load.

Code	A	Capacity	Wear Indicator
TRBC050T2	50	800Kg	Yes

GO GREEN





Trailer Ball Coupling - Cast iron

Acoplamiento De Bolas

- Suitable for Hitch ball of Ø50mm.
- Max. Bearing load S-150Kg.
- Towing load-300Kg.
- Product one handed operation.
- Prevent unintentionally opening with wear indicator.
- Opening by tilting the handle forward.
- Closes automatically by supporting load or pressure downwards .
- Malleable cast iron suitable for longitude & cross screw connections.

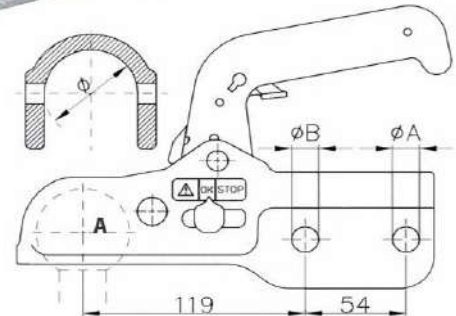

Code	A	Capacity	Wear Indicator
TRBC05CI	50	3500Kg	Yes

Trailer Bend Plate

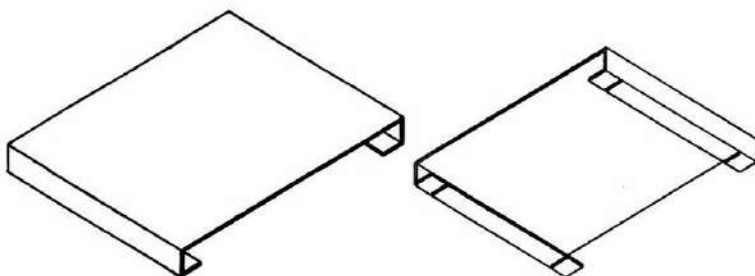

TRPLATE01

- IS-2062 prime material is used to made this plate
 - Finish : Self
- Weight of Plate : 0.314Kgs

Trailer Safety Chain Retainer

- Available in Size 1/4" & 3/8"

Code For 1/4" : TR5471000

Code For 3/8" : TR5471001

S. No.	Item Name	Material	Qty.	Finish
1	Chain Retainer	1030-1045 Forged Steel	1	Mill
2	Clevis Pin	Grade 5 Steel	1	Zinc Plated
3	Cotter Pin	Steel	1	Zinc Plated

Weight of 1/4" : 0.297Kgs, Weight of 3/8" : 0.450Kgs

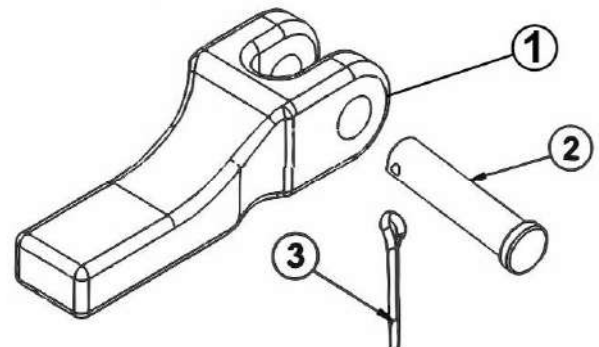



TRAILER KITS

Let's Win.... Together



TRAILER PARTS

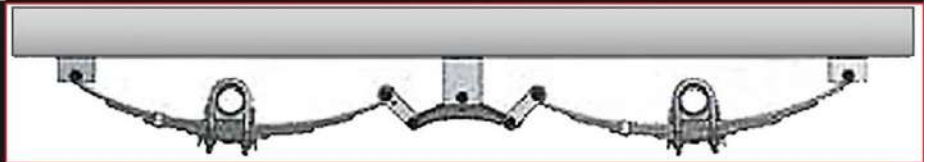



Trailer Axle Cargo Utility

"U" Bolt Kits for 5, 6 & 7K

 4 Bolts with 2 Brass Plates & 8 Flange Nuts

Our U-Bolt Kits include everything, you need to attach two Springs to an Axle. They are boxes and marked for you & your customers convenience.

Finish : Self, Packing : 2 Set per Box



Code	A	B	C	Application	Kit		
					Tie Plate	U-Bolt	Nut
4201	9/16"	3"	7"	5200-8000lb	2	4	8
4201L	1/2"	3"	7"	5200-7000lb	2	4	8
4202	1/2"	2.3/8"	5.1/2"	3500lb	2	4	8
4202L	7/16"	2.3/8"	5.1/2"	3500lb	2	4	8
4205	3/8"	1.3/4"	4.3/8"	2000lb	2	4	8

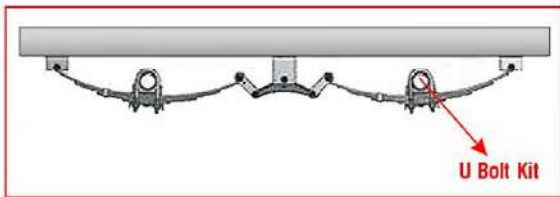
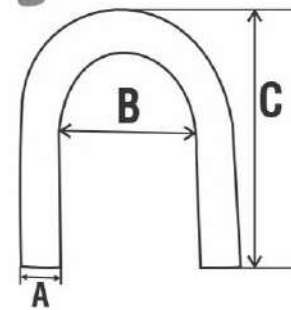

Trailer U-Bolt Kit 2.3/8"

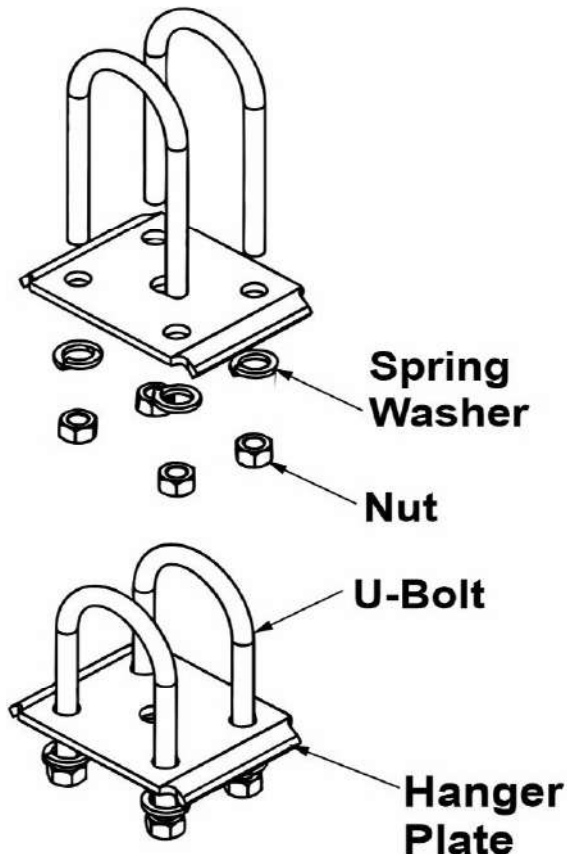

You can choose from different types of Trailer kits as per the requirement of your Axle.

We provide high grade nuts & bolts for strength of your coupling Axle with kit.

Finish : Self, Packing : 2 Set per Box

TRKTTK238-4202,4202L

S. No.	Item Code	Description	Finish	Qty.
1	TRPL238	Hanger Plate	Self	2
2	TRUB238	U-Bolt	Self	4
3	TRN1/2	Nut	Self	8
4	TRW217	Spring Washer	White ZP	8





Trailer U-Bolt Kit 3"

TRKTTK3-4201 (1/2")

S. No.	Item Code	Description	Finish	Qty.
1	TRPL003	Hanger Plate	Self	2
2	TRUB003	U-Bolt	Self	4
3	TRN1/2	Nut	Self	8
4	TRW217	Spring Washer	White ZP	8

Finish : Self, Packing : 2 Set per Box

Weight of Complete Set : 2.74 Kgs

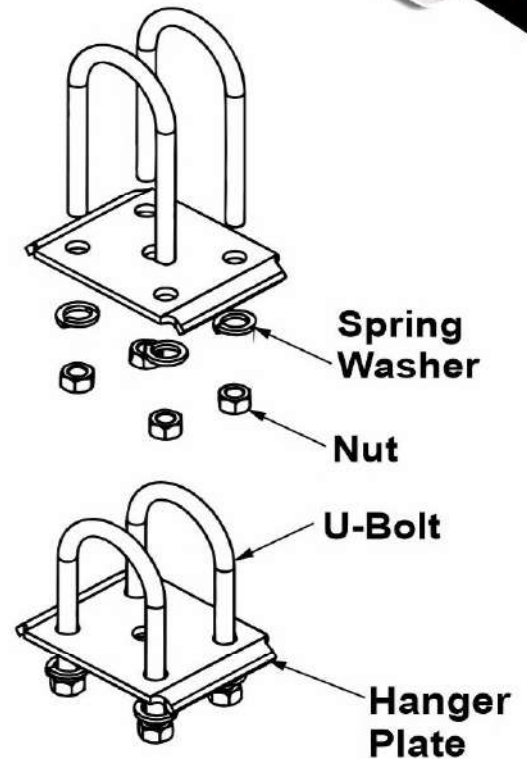
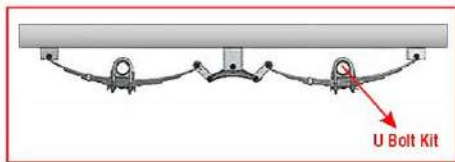

Trailer Kit - Double

TRKTTK3D

S. No.	Item Code	Description	Finish	Qty.
1	TRPL003	Hanger Plate	Self	4
2	TRUB003	U-Bolt	Self	8
3	TRN1/2	Nut	Self	16
4	TRW217	Spring Washer	White ZP	16

Finish : Self, Packing : 1 Set per Box

Weight of Complete Set (2) : 5.48 Kgs

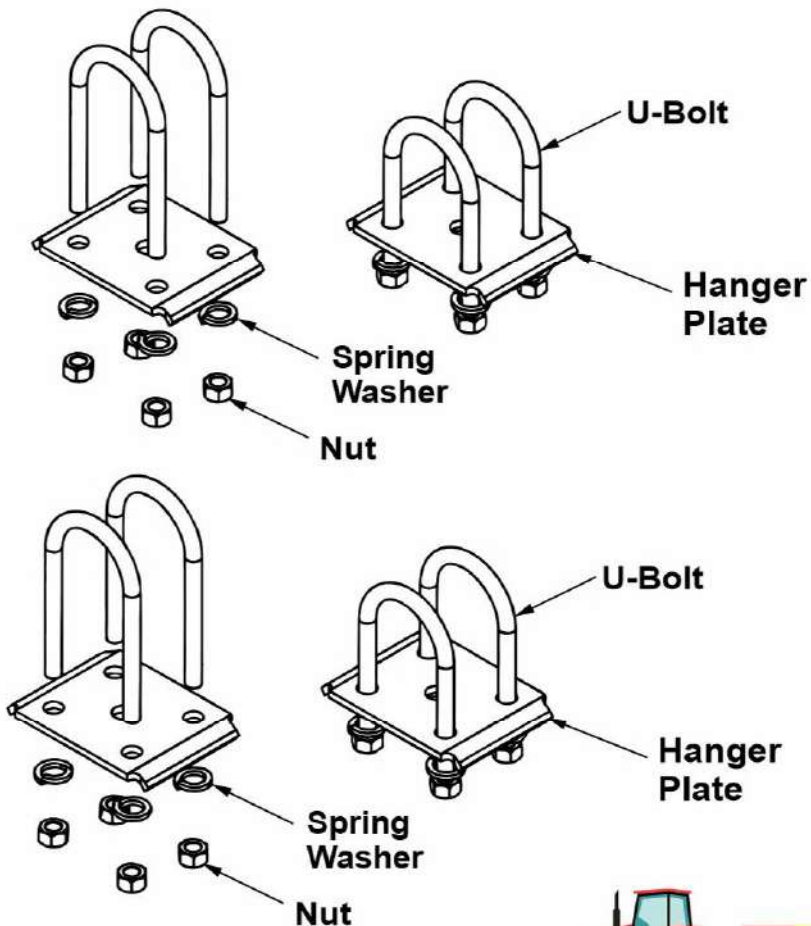



Trailer Slipper Hanger Kit -AP2T3S

- For 2" slipper spring 7000lbs tandem Axle.
- Attaches 4 of 2" wide slipper leaf springs to your trailer frame.
- The hanger kits need to be welded onto Trailer frame.
- No Spring included.
- Weight of Complete Set : 17.25 Kgs net.



TR5HK001

S. No.	Description	Qty.	Material	Wt./Pc
1	SM Part-1	2	LC(Prime Material)	3.550Kg
2	SM Part-2	2	LC(Prime Material)	1.705Kg
3	SM Part-3	2	LC	0.971Kg
4	SM Part-3	2	LC	1.532Kg
5	Bolt 7/8-19 with Grease Nipple	2	Grade 8.8	0.425Kg
6	Nut 7/8-19	2	LC	0.079Kg
7	Bolt-9/16-18	8	Grade 8.8	0.129Kg
8	Nut 9/16-18	8	LC	0.025Kg

Trailer Single Hanger Kit (Small)

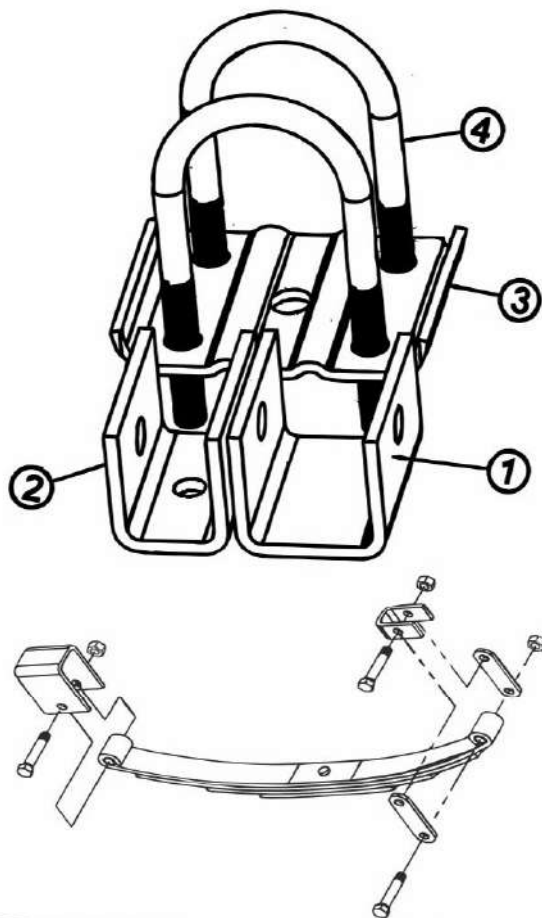

You can chose from different size of the hanger kits as per the fitment of your Trailer Axle.

They are designed and tested practically in-house by our engineers

Weight of Complete Set : 1.737 Kgs

TR5HK5

S. No.	Part Description	Qty.	Material	Finish	Wt./Pc
1	U Bracket 1	1	ST-52	Self	0.446Kg
2	U Bracket 2	1	ST-52	Self	0.390Kg
3	Bend Plate	1	ST-52	Self	0.395Kg
4	U Bolt	2	C10/C29	Self	0.253Kg





Trailer Tandem Hanger Kit (Medium)

TRTHKM

S. No.	Part Description	Qty.	Material	Finish	Wt./Pc
1	U Bracket	2	ST-52	Self	0.582Kg
2	Bend Plate	1	ST-52	Self	0.385Kg
3	U Bolt	2	C10/C20	Self	0.253Kg

Weight of Complete Set : 2.06 Kgs

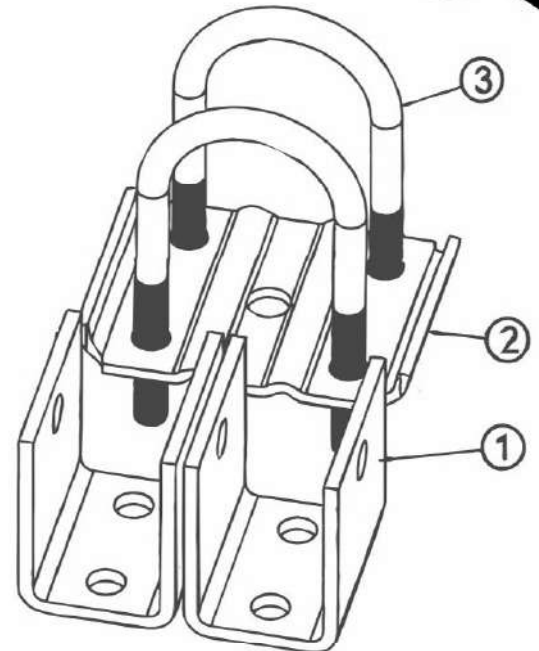

Trailer Tandem Kit

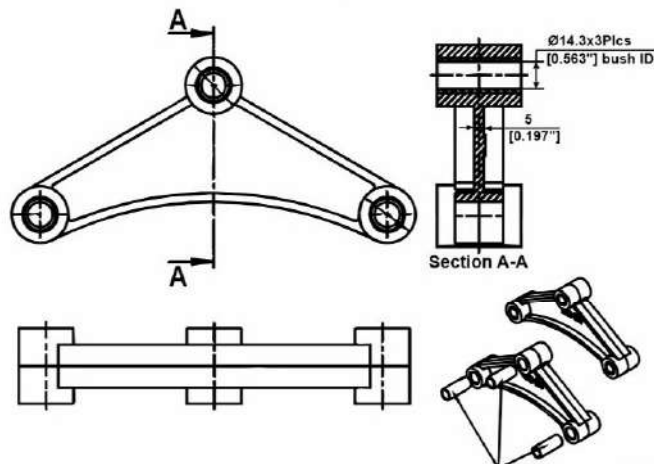

Trailer Axle Shackle kit for double eye springs tandem Axle suspension is made from high quality steel for ultimate durability and perfect match, it is 100% quality tested, less expensive & easy to install with good performance. it is compatible with 1.3/4" wide double eye spring for 2000-7000 lb Axle. it is typically use for 3500 lb Axles.

- Enhance Performance.
- Easy Installation.
- High Reliability.
- Good Performance.

TRTAK001

S. No.	Part description	Qty.	Wt./Pc.	Total Wt./Pc.
1	Tandem Axle	2	1.105Kgx2	2.210Kg
2	Plastic Bush	6	0.0006Kgx6	0.0036Kg
3	Bolt 9/16"	14	0.114Kgx14	1.596Kg
4	Nut 9/16"	14	0.026Kgx14	0.364Kg
5	Plane Strip	8	0.113Kgx8	0.904Kg
6	U Bend (SM Part)	6	0.635Kgx6	3.810Kg

Weight of Complete Set : 8.887 Kgs





Trailer Single Axle Suspension Kit

Trailer Single Axle Suspension kit for double eye leaf springs is for 2000-7000lbs axles. Typically used on 3500lb Axles. Spring Hangers are meant to be welded on.

TRSAK002

S. NO.	Part Description	Qty.	Wt./Pc.	Total Wt./Pc.
1	Shackle Links 3.125"	4	0.113KgX4	0.452Kg
2	Front & Rear Hangers	4	0.486KgX4	1.944Kg
3	Bolt 9/16"	6	0.114KgX6	0.684Kg
4	Nut 9/16"	6	0.026KgX6	0.156Kg

Weight of Complete Set : 3.236 Kgs



Trailer Leaf Spring

JRS Farm Parts leaf spring are easy to install, protect vehicle from impact, made from high quality metal material, light weight and portable to carry. it can withstand high temperature, strong wind and sunlight without affecting its normal visual effects.

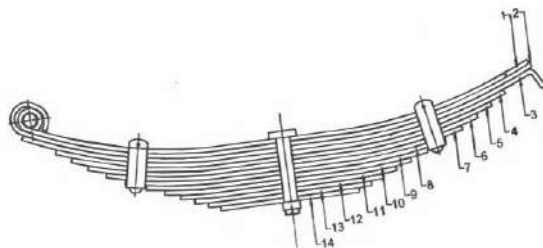

ES66065000

Item code	Section	Shearing Length	Finished Length	C. Hole	Eccentricity	Min. Wt. (in Kgs)
TRES66065000-1	100x15 Thickness	1295	C/E 1120	16.5 (+0.5 -0.0)	532+588	12.506
TRES66065000-2		1295	C/E 1120		532+588	12.506
TRES66065000-3		1170	E/E 1120		532+588	12.506
TRES66065000-4		844	844		422+422	9.421
TRES66065000-5		796	796		398+398	8.882
TRES66065000-6		734	734		367+367	8.187
TRES66065000-7		676	676		338+338	7.536
TRES66065000-8		626	626		313+313	6.975
TRES66065000-9		626	626		313+313	6.975
TRES66065000-10		528	528		264+264	5.875
TRES66065000-11		472	472		236+236	5.247
TRES66065000-12		418	418		209+209	4.641
TRES66065000-13		370	370		185+185	4.112
TRES66065000-14		304	304		152	3.371

Material : SUP-11A

Finish : Black Paint

Weight of Complete Set : 152 Kgs





Trailer Leaf Spring Assy.

E566063000

Sr. No.	Section	Shearing Length	Finished Length	C. Hole	Eccentricity
1	100x15 Thickness	1176	1176	16.5 (+0.5 -0.0)	588+588
2		1176	1176		588+588
3		1276	E/E 1176		588+588
4		822	822		411+411
5		764	764		382+382
6		708	708		354+354
7		650	650		325+325
8		586	586		293+293
9		484	484		242+242
10		426	426		213+213
11		366	366		183+183
12		304	304		152+152

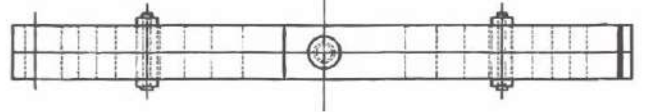
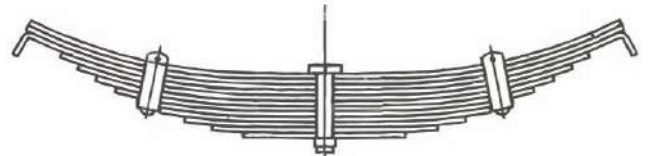

Material : SUP-11A
 Finish : Black Paint
 Hardness : 363-429 BHN

Sr. No.	Designation	Size	Material	Qty.
1	Center Bolt	M16x2Px208mm	10.9 Grade	1
2	Hex Nut	M16x2P	10 Class	1
3	Spacer	Ø12xØ14x104	M.S.	2
4	Clamp	25x6	M.S.	2
5	Hex Bolt	M10x1.5Px128mm	M.S.	2
6	Hex Nut	M10x1.5p	M.S.	2
7	Rivet	Ø10x28	M.S.	2

Trailer 12 Leaves Spring Assy.

E566064000



Material : SUP-11A
 Finish : Black Paint
 Hardness : 363-429 BHN

Sr. No.	Section	Shearing Length	Finished Length	C. Hole	Eccentricity
1	100x15 Thickness	1295	C/E 1120	16.5 (+0.5 -0.0)	532+588
2		1295	C/E 1120		532+588
3		1170	E/E 1120		532+588
4		844	844		422+422
5		796	796		398+398
6		734	734		367+367
7		676	676		338+338
8		626	626		313+313
9		514	514		257+257
10		444	444		222+222
11		307	370		185+185
12		304	304		152+152

Sr. No.	Designation	Size	Material	Qty.
1	Center Bolt	M16x2Px208mm	10.9 Grade	1
2	Hex Nut	M16x2P	10 Class	1
3	Spacer	Ø12xØ14x104	M.S.	2
4	Clamp	25x6	M.S.	2
5	Hex Bolt	M10x1.5Px128mm	M.S.	2
6	Hex Nut	M10x1.5p	M.S.	2
7	Rivet	Ø10x28	M.S.	2
8	Bush	Ø30xØ38x97	Bronze	1



Trailer Leaf Spring

Finish : Black Painted
 Hardness : 363-429 BHN
 Weight of Complete Set : 4.601Kgs

TR5W4B

Sr. No.	Designation	Finish	Material	Qty.	Min. Wt.
1	Leaf Spring 44x8Thk	Black Painted	SUP9A	4	4.545Kg
2	Plastic Bush	White	Prime Plastic	2	0.002Kg
3	Locking Strip	Sell	Spring Steel	1	0.022Kg
4	Round Head Bolt 3/8x24	Auto Black	8.8 Grade	1	0.026Kg
5	Hex Nut 3/8-24	Auto Black	M.S	1	0.006Kg

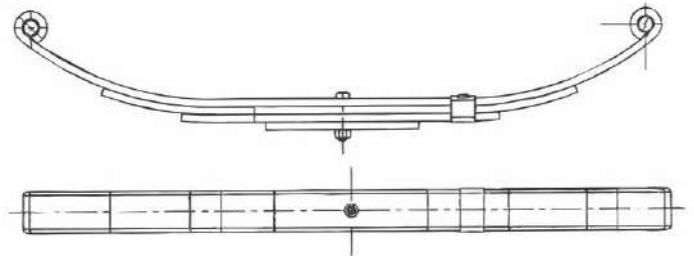

Trailer Leaf Spring



TRE-5115

Sr. No.	Designation	Finish	Material	Qty.	Min. Wt.
1	Leaf Spring 51x10Thk	Black Painted	SUP9A	6	12.395Kg
2	Plastic Bush	White	Prime Plastic	1	0.003Kg
3	Locking Strip	Sell	Spring Steel	1	0.034Kg
4	Round Head Bolt 3/8x24	Auto Black	8.8 Grade	1	0.051Kg
5	Hex Nut 3/8-24	Auto Black	M.S	1	0.006Kg

Hardness : 363-429 BHN
 Weight of Complete Set : 12.490 Kgs

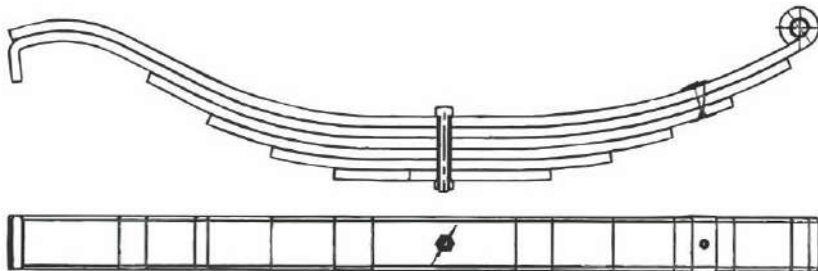

GO GREEN!





Trailer Wheel Hub Axle

Semiejes Sin Freno
Semiejes Sin Freno A6 Fori

Sr. No.	Code	Hub Ø(mm)	H(mm)	L(mm)	Capacity(Kg)
1	TRWHA12530	125	30	206	300
2	TRWHA12535	125	35	206	300
3	TRWHA12530B	125	30	406	300
4	TRWHA12535B	125	35	406	300
5	TRWHA14040	140	40	406	500
6	TRWHA14045	140	45	406	500

Finish : Self with RPO/Powder Coating
Hub Material : Sgiron
Axle material : EN8D
Bearing : 6204-2RS
Cap : S355-J2

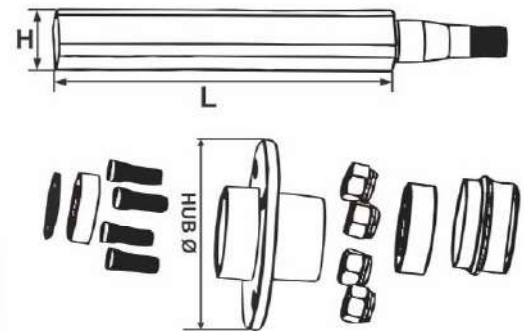

- 👉 An Axle plays a role of foundation for Trailers and without the right Quality Axles, Trailers carrying goods can be at Risk.
- 👉 We have quality tested steel grades from approved vendors of Raw Material (Steel) such as TATA, AVON ISPAT & JINDAL

Trailer Bare Axle

Sr. No.	Code	Thread Size (T)	H(mm)	L(mm)
1	TRBA30276	M18x1.5x21	30	276
2	TRBA35276	M18x1.5x21	35	276
3	TRBA30476	M18x1.5x21	30	476
4	TRBA35476	M18x1.5x21	35	476

Finish : Self with RPO/Powder Coating
Material : EN8D/C20

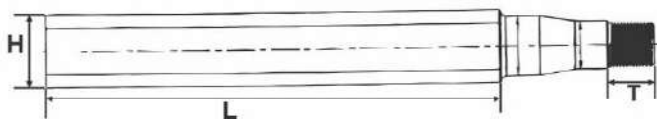



Jockey Wheels



Parking Jacks



Let's Win... Together





Trailer Standard Jockey Wheel

Apoyos Rueda Estandap
Servotimone leggero A Ruota

Code	Pipe Diameter (ØA)	Wheel Size	Pipe Length	B	C	D
EJW001	35	160x43	220	310	100	465
EJW002	42	200x50	195	390	120	590
EJW003	48	200x50	195	390	120	590
EJW004	48	250x85	175	420	150	625
EJW005	60	255x80	400	430	150	720
EJW006	60	220x70	500	560	350	1060

- High Quality, OEM Standards.
- Easy Installation.
- Finish : Electro Plating.
- Buy **JRS** Jockey Wheel Clamp for better results in fitting.
- Load tested Tyres.

 We offer wide variety of Jockey Wheel with solid tyres and moulded Plastic handles to reduce the effort of operating the device.

 Our Jockey Wheels are Load tested and developed as per standards set worldwide.

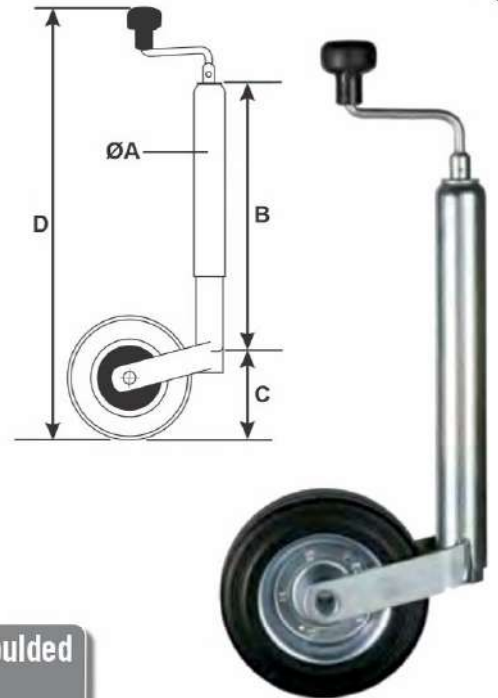

Trailer Automatic Jockey Wheel

Apoyos Rueda Jockey Automatic
Servotimone A Ruota Ribaltabile

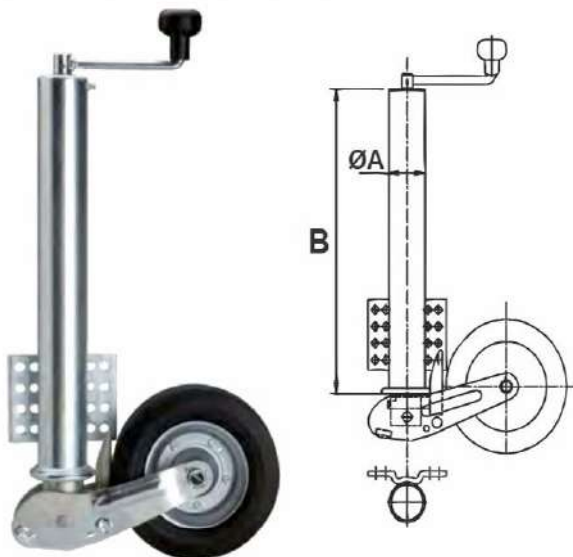

Code	Pipe Diameter (ØA)	Wheel Size	Capacity (Kg)	B
EJWA001	60	200x60	300	470
EJWA002	60	200x60	300	570

- High Quality, OEM Standards.
- Easy Installation.
- Finish : Electro Plating.
- Buy **JRS** Jockey Wheel Clamp for better results in fitting.
- Load tested Tyres.



GO GREEN!





Trailer Automatic Jockey Wheel

Apoyos Rueda Jockey Automatic
Servotimone A Ruota Ribaltabile

Code	Pipe Diameter (ØA)	Wheel Size	Capacity (Kg)	B
EJWA002HD	60	200x60	300	437

- High Quality, OEM Standards.
- Easy Installation.
- Finish : Electro Plating.
- Buy JRS Jockey Wheel Clamp for better results in fitting.
- Load tested Tyres.



Retracting Wheel : with the help of automated mechanism, the Wheel is retracted which eliminates the possibility of swiveling.

Rim : Available in Polypropylene & Steel.

Trailer Automatic Jockey Wheel - Square Design

Apoyos Rueda Jockey Automatic
Servotimone A Ruota Ribaltabile

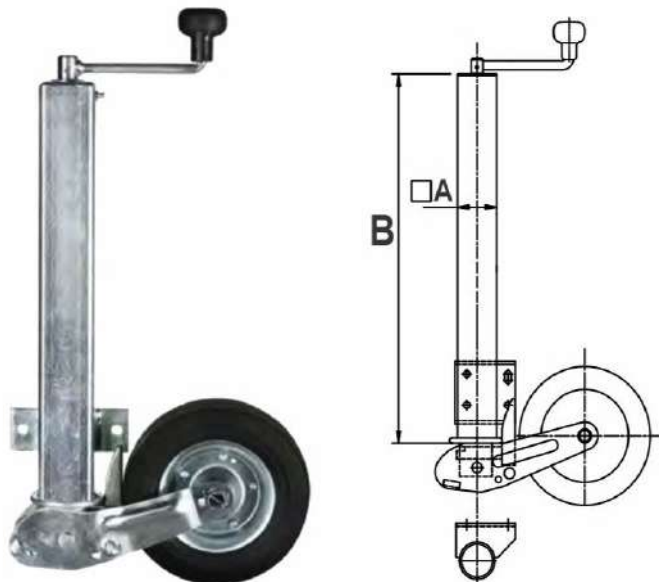

Code	Pipe Width □A	Wheel Size	Capacity (Kg)	B
EJWA006	60x4	200x60	300	470
EJWA007	60x4	200x60	300	570

- High Quality, OEM Standards.
- Easy Installation.
- Finish : Electro Plating.
- Buy JRS Jockey Wheel Clamp for better results in fitting.
- Load tested Tyres.



GO GREEN!







Trailer Premium Jockey Wheel - With Ribs

Code	A	Tyre	B	Load	Wt.
TPJWR00486	48	150	507	400Kg	4.50
TPJWR00486C	48	150	507	400Kg	4.50
TPJWR00488	48	200	567	400Kg	6.00
TPJWR00488C	48	200	567	400Kg	6.00



-  Premium Jockey Wheel are suitable for RV Trailers with solid & strong tyres available in both Polypropylene & Zinc plated surface.
-  Premium Jockey Wheel is available in both with clamps and without clamps.
-  Tyre Sizes are also available in large sizes for soft surface which helps in easier movement.

Trailer Premium Jockey Wheel - Without Ribs

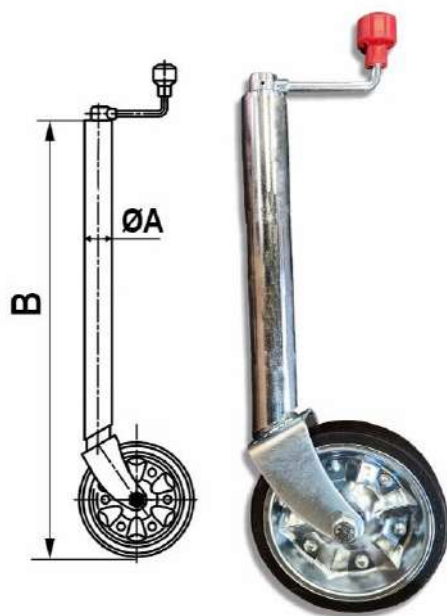

Code	A	Tyre	B	Load	Wt.
TPJWC0486	48	150	510	400Kg	7.0
TPJWC0488	48	200	570	400Kg	8.5
TPJWC04810	48	250	630	400Kg	11.0

- High Quality, OEM Standards.
- Easy Installation.
- Finish : Electro Plating.
- Buy **JRS** Jockey Wheel Clamp for better results in fitting.
- Load tested Tyres.



Trailer Premium Power Mover Jockey Wheel

Power Mover is convenient for moving Caravan or Trailer without much effort. The mechanism is strong enough for moving Caravans. This premium Jockey Wheel can be moved in three functions-forward, reverse & stop/lock & It can be lifted to a height of 840mm.

Code	Pipe Diameter (ØA)	Wheel Size	Wt.(Kg)	B
TPPMJW	48	200	14.5	510

- 10" solid Rubber Wheel.
- Raises to Height 840mm.
- Static capacity 350Kgs, Dynamic Capacity 150Kgs
- Emergency Stop feature.
- Can be moved Forward & Reverse.
- Easy to Move.
- Clamps also available, suitable for fit with our Premium Jockey Wheel.

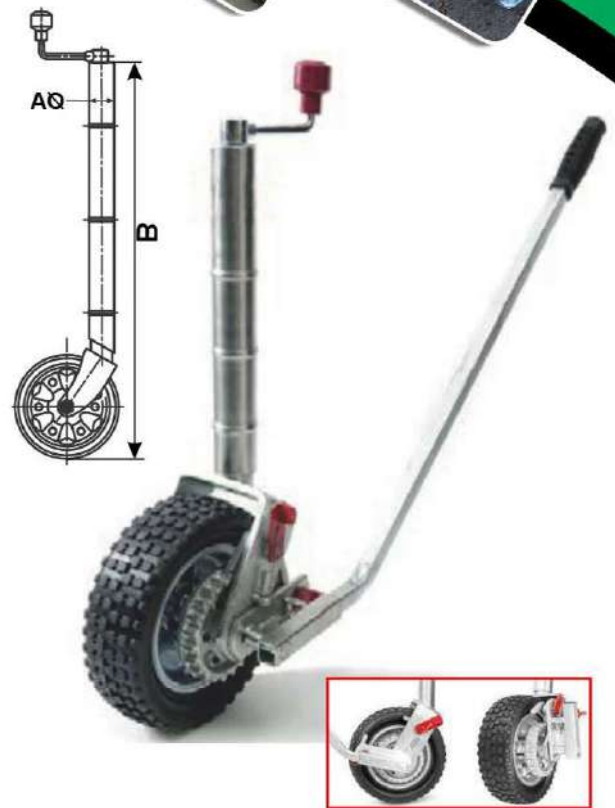

Trailer Parking Jack - Heavy Type

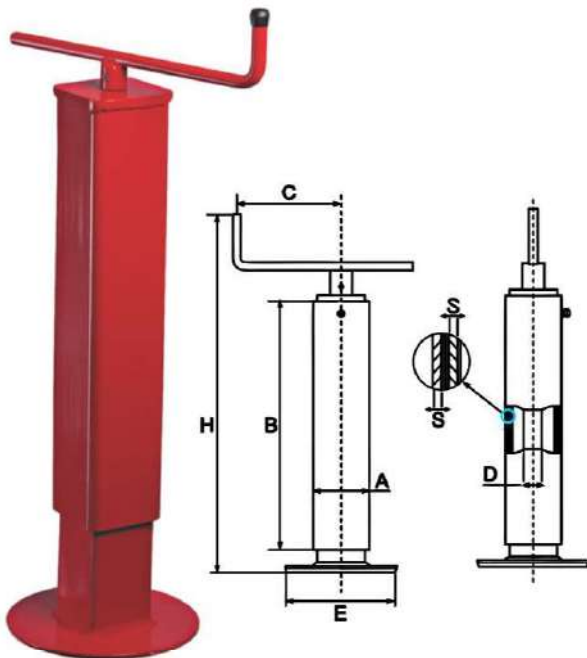

CODE	Dim. A	Dim. B	Dim. C	E	H	S	D	Stroke	Static Cap.
E10101	40	300	115	95	440	2	18	150	400
E10102	40	400	115	95	540	2	18	250	400
E10103	40	500	115	95	640	2	18	350	400
E10105	50	300	135	160	480	3	22	150	800
E10106	50	400	135	160	580	3	22	250	800
E10107	50	500	135	160	680	3	22	350	800
E10108	50	600	135	160	780	3	22	500	800
E10109*	50	400	135	160	580	3	22	250	800
E10113	60	400	135	160	580	3	22	250	1000
E10114	60	500	135	160	680	3	22	350	1000
E10115	60	600	135	160	780	3	22	500	1000
E10116	60	700	135	160	880	3	22	500	1000
E10117*	60	500	135	160	680	3	22	350	1000
E10130*	70	400	180	160	580	3	28	300	1800
E10131*	70	500	180	160	680	3	28	400	1800
E10132*	70	600	180	160	780	3	28	500	1800
E10133*	70	700	180	160	880	3	28	500	1800
E10135*	80	400	180	220	590	3	28	300	2000
E10136*	80	500	180	220	690	3	28	400	2000
E10137*	80	600	180	220	790	3	28	500	2000
E10139*	100	500	180	220	690	4	28	400	2200
E10140*	100	700	180	220	890	4	28	500	2200





Trailer Parking Jack - Heavy Type without Footplate

CODE	Dim. A	Dim. B	Dim. C	H	S	D	Stroke	Static Cap.
E10102SP	40	400	115	535	2	18	250	400
E10106SP	50	400	135	565	4	22	250	800
E10113SP	60	400	135	1256	4	22	250	1000
E10131SP	70	500	180	665	4	28	400	1800
E10136SP	80	500	180	665	4	28	400	2000

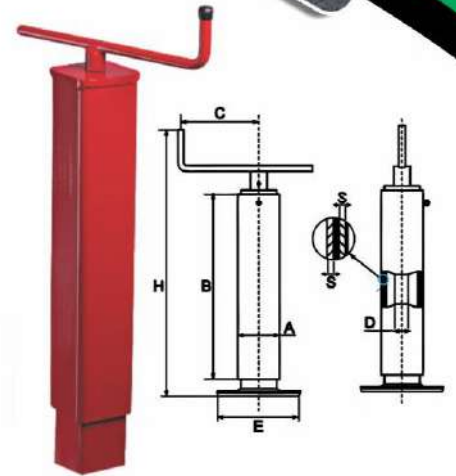

Trailer Parking Jack - With Lateral Handle

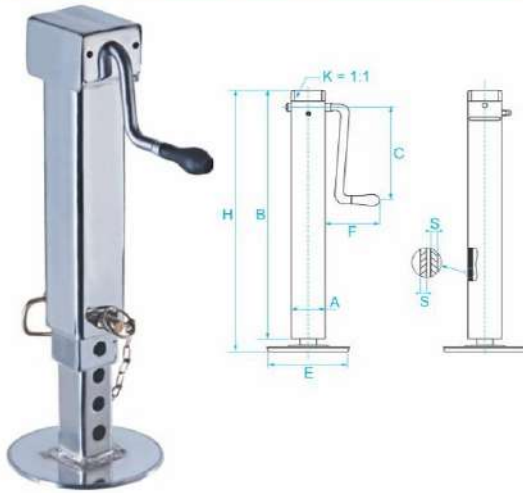

CODE	Dim. A	Dim. B	Dim. C	E	F	H	S	Stroke	Static Cap.
E10399*	60	550	170	160	150	565	3	350	1000
E10400	60	550	170	160	150	580	3	350	1000

Trailer Parking Jack - Heavy Duty

With Reduction Gear & Lateral Handle

CODE	Dim. A	Dim. B	Dim. C	E	F	H	S	Stroke	Static Cap.
E10402	70	500	220	220	185	620	3	400	3000
E10404	70	600	220	220	185	720	3	500	3000
E10406	70	700	220	220	185	820	3	500	3000
E10407	70	800	220	220	185	920	3	500	3000
E10403	80	500	220	220	180	620	3	400	3000
E10405	80	600	220	220	180	720	3	500	3000
E10408	80	800	220	220	180	920	3	500	3000

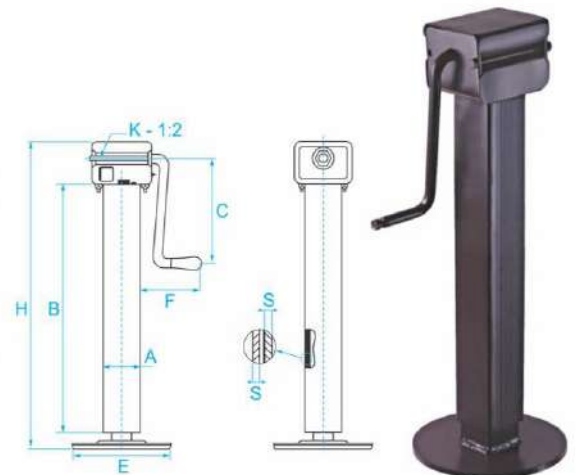



Trailer Parking Jack - Light Type

CODE	Dim. A	Dim. B	Dim. C	E	H	SE	SI	D	Stroke	Static Cap.
E10102E	40	360	115	95	500	2	2	18	250	400
E10116E	60	660	115	160	840	3	2	18	450	700
E10122E	50	460	115	160	610	3	2	18	250	600
E10123E	50	560	115	160	710	3	2	18	350	600
E10126E	60	460	115	160	610	3	2	18	350	700
E10127E	60	560	115	160	710	3	2	18	450	700
E10131E*	70	460	180	160	640	3	3	22	350	1200
E10132E*	70	660	180	160	840	3	3	22	500	1200
E10133E*	70	660	180	160	840	3	3	22	500	1200



Trailer Parking Jack - Normal Type



CODE	Dim. A	Dim. B	Dim. C	E	H	SE	SI	D	Stroke	Static Cap.
E10120	50	260	115	160	410	3	2	18	150	600
E10121	50	360	115	160	510	3	2	18	250	600
E10122	50	460	115	160	610	3	2	18	250	600
E10123	50	560	115	160	710	3	2	18	350	600
E10125	50	360	115	160	510	3	2	18	250	700
E10126	50	460	115	160	610	3	2	18	250	700
E10127	50	560	115	160	710	3	2	18	450	700

Trailer Jockey Wheel Clamp

Abrazadera Para Rueda Jockey
Morsetto Supporto Fissaggio Ruotino Rimorchio

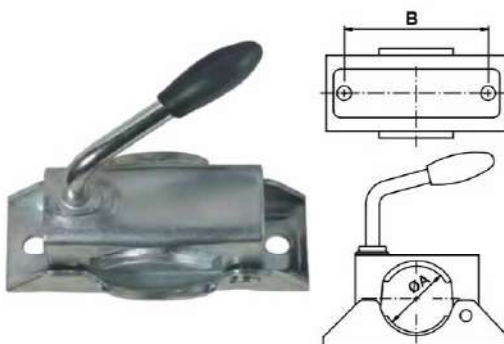

Code	ØA	B	Load
JWC0035	35	105	250Kg
JWC0048	48	105	250Kg
JWC0060	60	105	250Kg

- Fit for all type of Jockey Wheel Ø35, Ø48 & Ø60.
- Easy Installation.

GO GREEN





Trailer Jockey Wheel Clamp - Long Handle

Abrazadera Para Rueda Jockey
Morsetto Supporto Fissaggio Ruotino Rimorchio

Code	ØA	B	Load
JWCL0035	35	105	250Kg
JWCL0048	48	105	250Kg
JWCL0060	60	105	250Kg

- Fit for all type of Jockey Wheel Ø35, Ø48 & Ø60.
- Easy Installation.

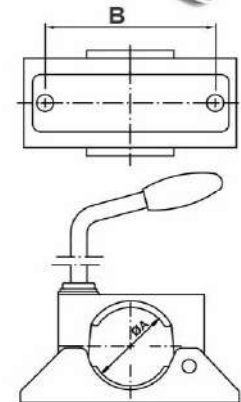

Trailer Jockey Wheel Clamp - With Moving Handle

Abrazadera Para Rueda Jockey
Morsetto Supporto Fissaggio Ruotino Rimorchio

Code	ØA	B	Load
JWCM0035	35	105	250Kg
JWCM0048	48	105	250Kg
JWCM0060	60	105	250Kg

- Fit for all type of Jockey Wheel Ø35, Ø48 & Ø60.
- Easy Installation.

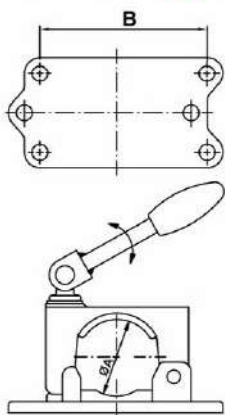

Trailer Silencer Clamp

CODE	Dim. A mm	Dim. A mm	Dia. ØC mm	Dim. D mm	Dim. E mm	Dim. F mm
ESLA01	76.2	44.45	12.7	3.17	135	108
ESLA02	82.2	54.3	19.05	6	150	107.95
ESLA03	74	37.5	12.7	5	163	43
ESLA04	119	41.5	12.7	5	222	76
ESLA05	140	47.5	16	5	266	142

- With 2 round Caliper Clamps you can quickly & easily equip a Jockey Wheel on a Car Trailer.
- Available in Box packaging.
- Shackle Dia is 10mm.
- Helpful in upgrading a Jockey Wheel.



GO GREEN





Trailer Binder Support for Jockey Wheel - Round

Silencer Clamp

Code	ØA	Support Pipe	Load (Kg)
JBS0035R	35	Round	250
JBS0048R	48	Round	250
JBS0060R	60	Round	250
JBS0070R	70	Round	250

- With 2 round Caliper Clamps you can quickly & easily equip a Jockey Wheel on a Car Trailer.
- Available in Box packaging.
- Shackle Dia is 10mm.
- Helpful in upgrading a Jockey Wheel.

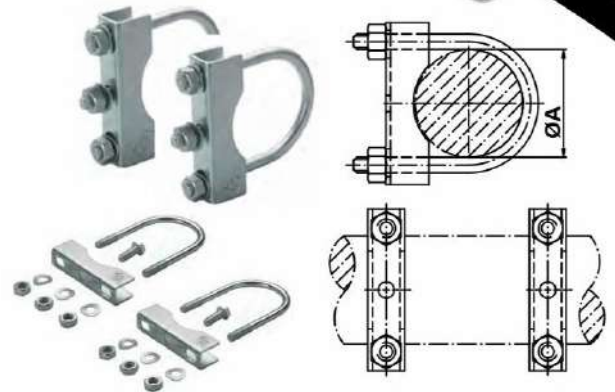

Trailer Binder Support for Jockey Wheel - Square

Silencer Clamp

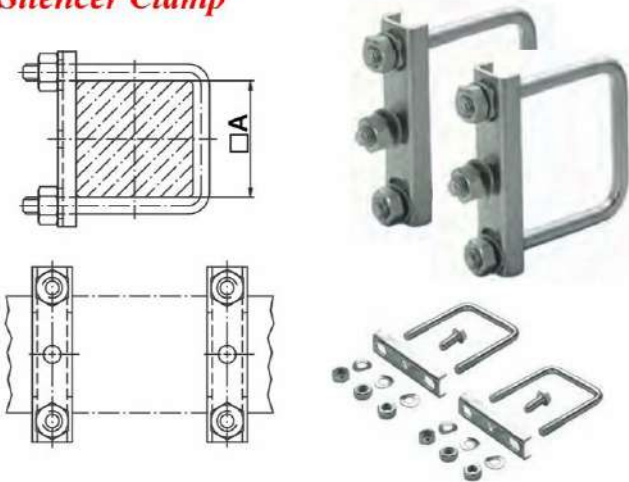

Code	A	Support Pipe	Load (Kg)
JBS0035S	35	Square	250
JBS0048S	48	Square	250
JBS0060S	60	Square	250
JBS0070S	70	Square	250

- With 2 round Caliper Clamps you can quickly & easily equip a Jockey Wheel on a Car Trailer.
- Available in Box packaging.
- Shackle Dia is 10mm.
- Helpful in upgrading a Jockey Wheel.

Trailer Stand

Code	L	ØA	Load
TRSTAN48600	600	48	150
TRSTAN48700	700	48	150
TRSTAN48750	750	48	150
TRSTAN60600	600	60	250
TRSTAN60700	700	60	250

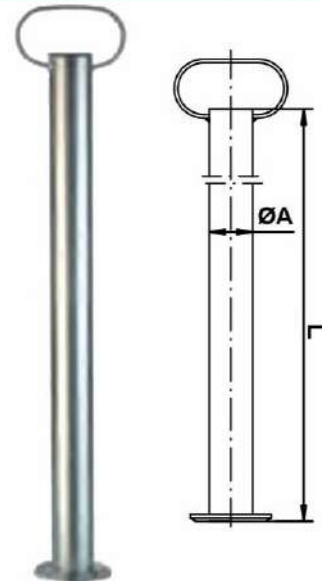



Trailer Binder Support for Jockey Wheel - Round

Code	L	ØA	ØC	Load
TST04890	370	48	90	150
TST048120	600	48	120	150
TST06090	370	48	90	250
TST060120	600	60	120	250



Trailer Clamp for Jockey Wheel

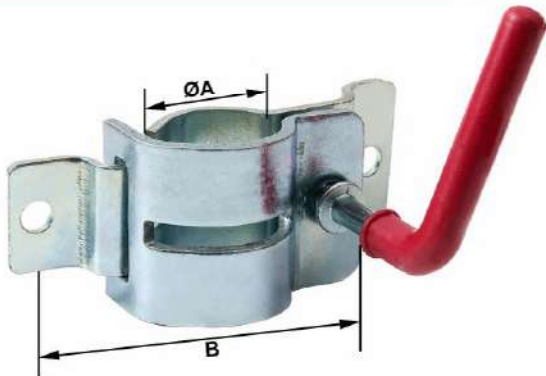

Code	ØA	B	Load
TRJWC0048	48	150	250

Trailer Double Clamp for Jockey Wheel

Code	ØA	B	Load
TRJWCD0048	48	150	250

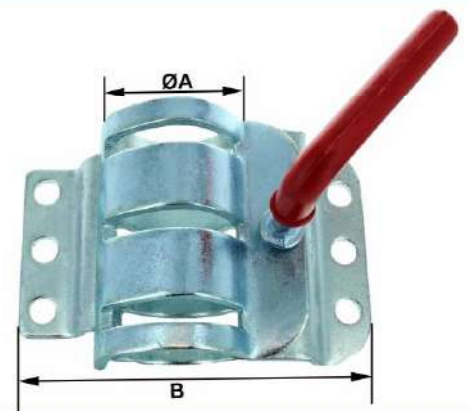

Handle for Trailer Clamp



Jockey Wheel clamp handle & wash included washer with plastic grip.





Trailer Locks - Anti Theft

- Trailer lock for over the Couplers

Code	A	T	C
TRL100	100	2	224

- ☞ Anti theft Trailer Lock for over the Coupling of the Trailers.
- ☞ Handle on Top of Lock for Easy accessibility.

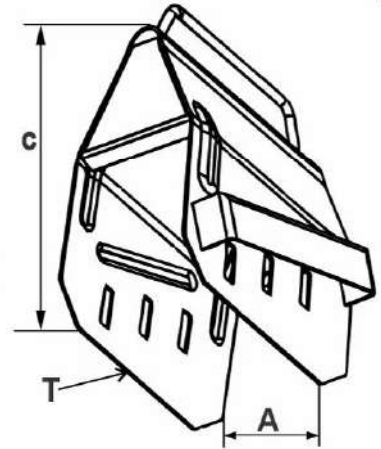

Trailer Lock Square - Anti Theft



- Trailer lock for over the Couplers
- Size : 230x110x110

Code	A	B	C
TRL230	110	230	224

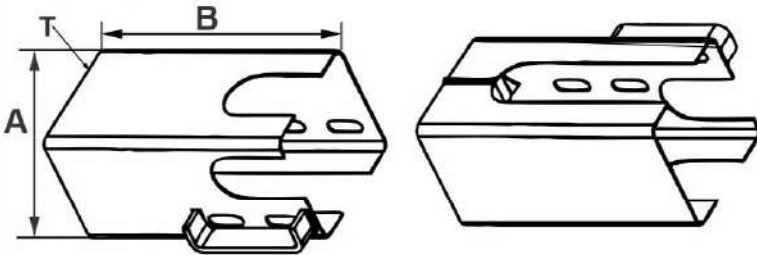

Trailer Lock Round - Anti Theft

- Trailer lock for over the Couplers

Code	A	T	B
TRL210	110	2	210

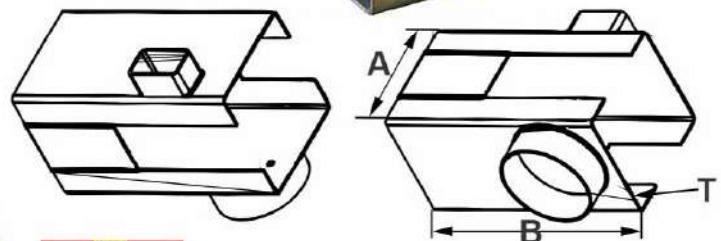



Trailer Side Board Lock

- Secure attachment.
- Easy to install.
- Finish : Electro Zinc Plated.

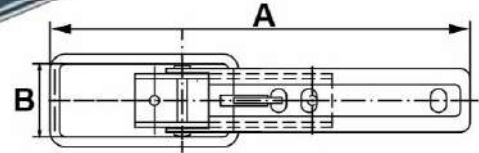

Code	A	B	Capacity
TR505070W	210	37	250

Trailer Lever With Handle - LH & RH

JRS Farm Parts Levers are tested in our in-house laboratory where we perform SPECTRO TEST, LOAD TEST etc. to ensure we supply right quality.

- Easy to handle.
- Easy to Adjust.
- Available in white & yellow Zinc plating.
- High grade nuts used for Assembly.

Code	Description
TR2218130061	Lever with Handle LH
TR2219130060	Lever with Handle RH

Weight of Complete Set : 0.830Kgs

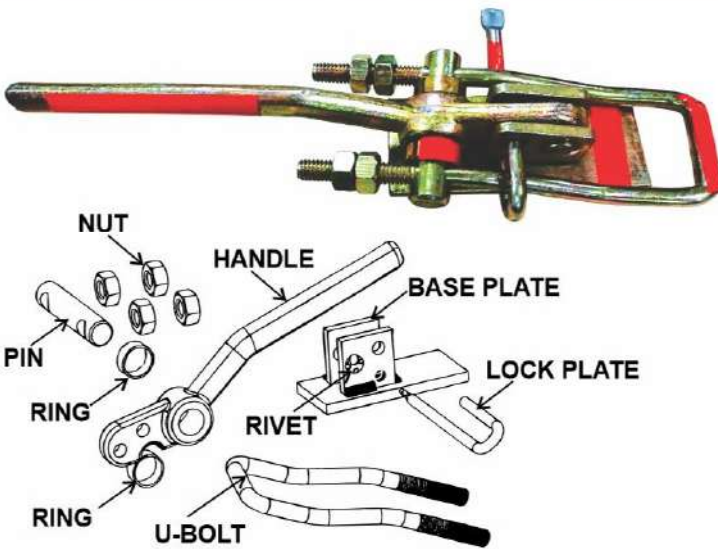

Trailer Silver Lock

- In house forged.
- Tested for in-house Commercial Vehicles.
- Tested as per International standards.
- Controlled dimensions as per IS : 2102-1993.
- Spring Steel used for better response on operations.

Code	Used for	A	B	C
TRTRAILERLOCK-L	Left	274	44	39
TRTRAILERLOCL-R	Right	274	44	39

- 👉 Our Trailer Locks are forged in-house with controlled dimensions on CNC machines.
- 👉 Our Trailers locks are tried & tested on our in-house commercial vehicles from past 3 years and has prove to be sturdy.

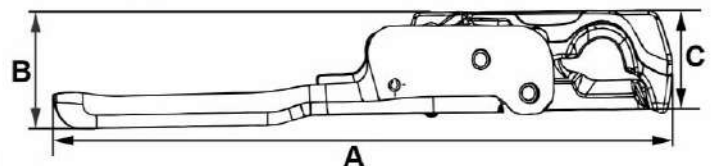



LATCH ASSEMBLIES



Let's Win.... Together





Trailer Fixed Latch Assembly

JRS Farm Parts manufacturers and export all types of Side Latches with strong foundation of quality infrastructure. Our Side Latches are finished in-house and they are easy to install.

- Secure attachment.
- Easy to install.
- Finish : Electro Zinc Plated.
- Applicable for Trucks, Trailers & Containers.
- Spring loaded safety latch help.

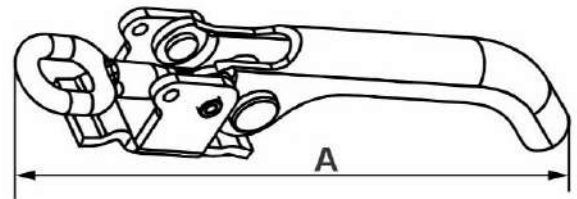

Code	A	Thickness	Capacity
TRFKA	230	4	250

Trailer Spring Tube Latch Assembly

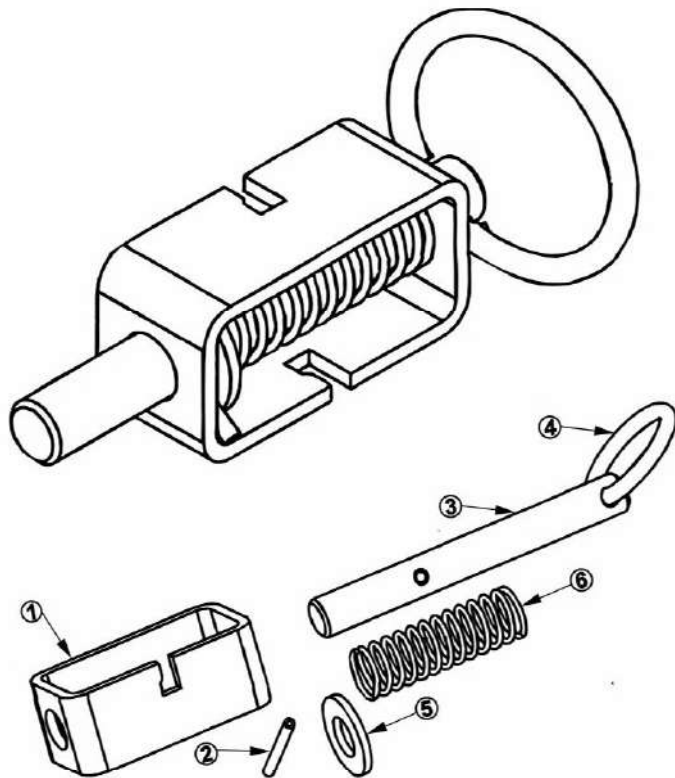

TR1159

S. No.	Description	Material	Finish	Qty.
1	Housing, Rectangular Plate	C.R.S.	Black Oxide	1
2	Coiled Pin, Ø4mmx45mm	65Mn Steel	Black Oxide	1
3	Pin	C.D.S.	Zinc Plated	1
4	Ring	C.D.S.	Zinc Plated	1
5	Washer	C.R.S.	Zinc Plated	1
6	Spring	Spring Steel	Zinc Plated	1

Weight of Complete Set : 0.450Kgs





Trailer Latch Assembly - 1260ZN01-Long

- We offer several type of bolt latches, including Barrel, Spring pull, Slam and Rotary latches.
- A Spring bolt latch uses a compressed spring to keep the bolt in the locked position.
- Our bolt latches come in Aluminium, Mild Steel & Stainless Steel .
- These are well made & sturdy bolt latch was just the right fit.

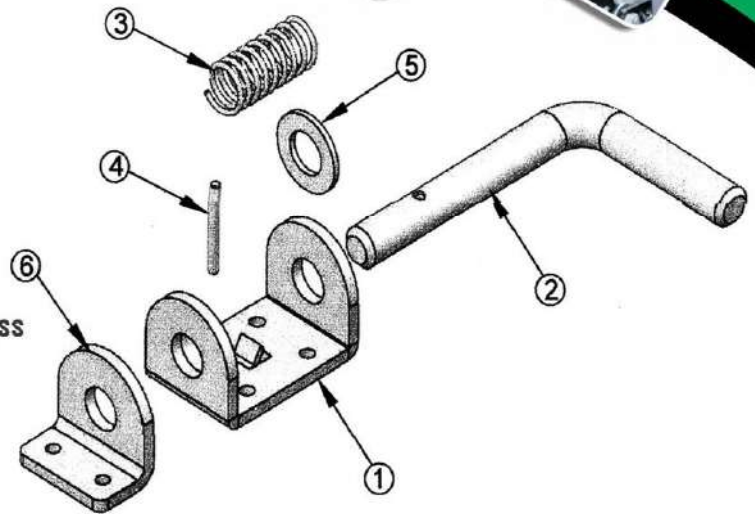

TRELP1260ZN01

S. No.	Item Name	Material	Qty.
1	Base	C.R.S (TATA Steel, Grade2)	1
2	Bolt	C.D.S.	1
3	Spring	Spring Steel	1
4	Knurled Pin	C.D.S.	1
5	Washer	C.R.S.	1
6	Keeper	C.R.S.	1

Weight of Complete Set : 1132Kgs

Trailer Latch Assembly - 1260ZN-Small

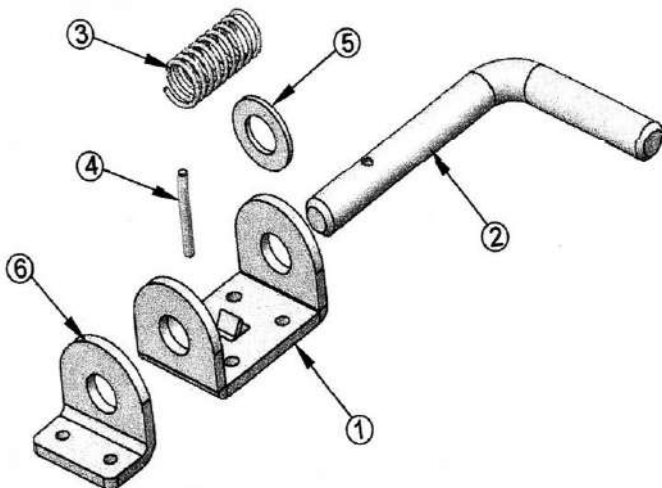

- We offer several type of bolt latches, including Barrel, Spring pull, Slam and Rotary latches.
- A Spring bolt latch uses a compressed spring to keep the bolt in the locked position.
- Our bolt latches come in Aluminium, Mild Steel & Stainless Steel .
- These are well made & sturdy bolt latch was just the right fit.

TRELP1260ZN

S. No.	Item Name	Material	Qty.
1	Base	C.R.S (TATA Steel, Grade2)	1
2	Bolt	C.D.S.	1
3	Spring	Spring Steel	1
4	Knurled Pin	C.D.S.	1
5	Washer	C.R.S.	1
6	Keeper	C.R.S.	1

Weight of Complete Set : 1000Kgs



Trailer Latch Pin Assembly

TRB2596LKB

S. No.	Item Name	Material	Qty.
1	Base Plate	C.R.S.	1
2	Handle	C.D.S.	1
3	Washer	C.R.S.	1
4	Spring Ø2.5	Spring Steel	1
5	Pin Øx44	C.D.S.	1
6	Bend Plate	C.R.S.	1

Weight of Complete Set : 1074Kgs

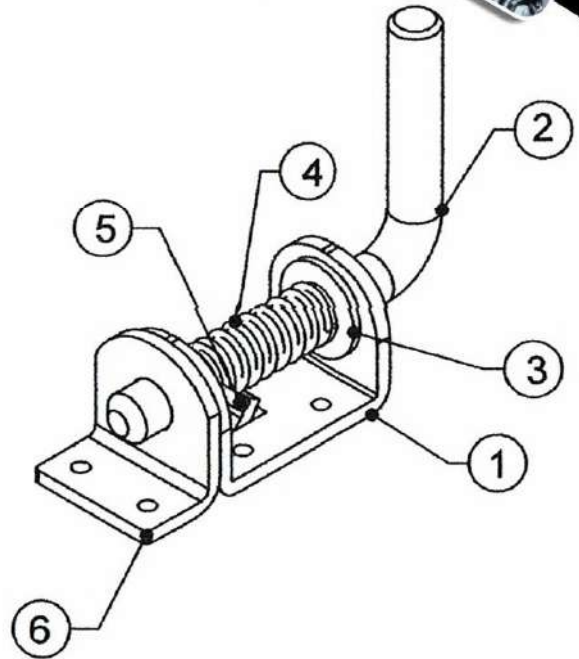

Trailer Latch Assembly

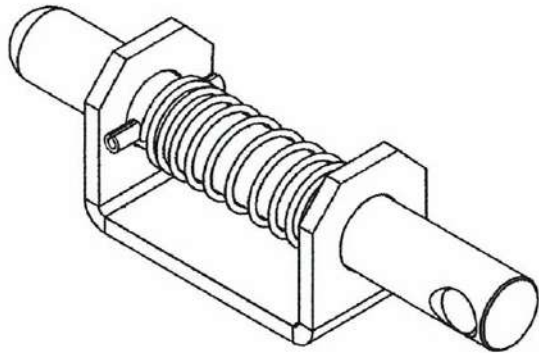

TR100U101

Weight of Complete Set : 0.550Kgs

Material : M.S., Dowel Pin & Spring Steel

Finish : Self

Trailer Latch Assembly - Heavy Duty With Keeper

TRHDLK1260M-01

S. No.	Item Name	Material	Qty.	Finish
1	Base	C.R.S.	1	Mill
2	Bolt	C.D.S.	1	White ZP (8µm Min.)
3	Spring	Spring Steel	1	White ZP (8µm Min.)
4	Ø5 Knurled Pin	C.D.S.	1	White ZP (8µm Min.)
5	Washer	C.R.S.	1	White ZP (8µm Min.)
6	Keeper	C.R.S.	1	White ZP (8µm Min.)

Weight of Complete Set : 0.975Kgs

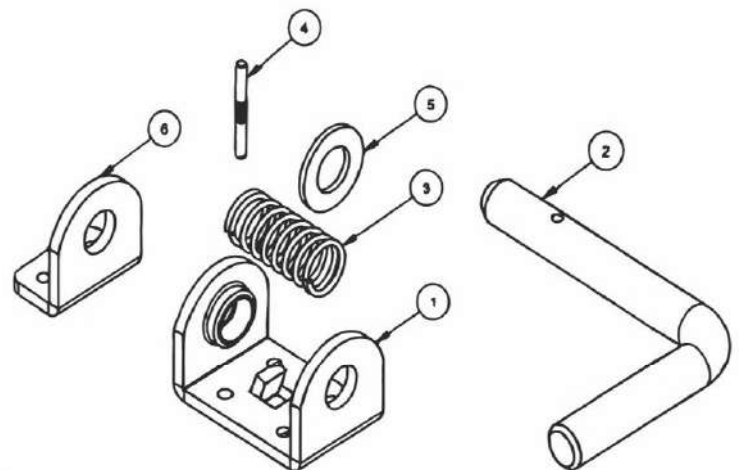



Trailer Latch Assembly - Short Spring Tube

TR1159-3

S. No.	Item Name	Material	Qty.	Finish
1	Housing, Rectangular Tubing	C.R.S.	1	Black Oxide
2	Coiled Pin, Ø4mmX45mm	65Mn. Steel	1	Black Oxide
3	Pin	C.D.S.	1	Zinc Plated
4	Ring	C.D.S.	1	Zinc Plated
5	Washer	C.R.S.	1	Zinc Plated
6	Spring	Spring Steel	1	Zinc Plated

Weight of Complete Set : 0.320Kgs

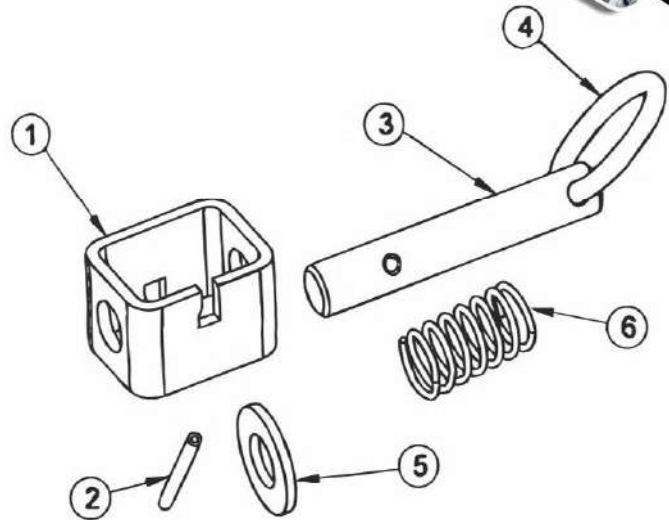

Trailer Latch Assembly - Heavy Duty

1260M-02

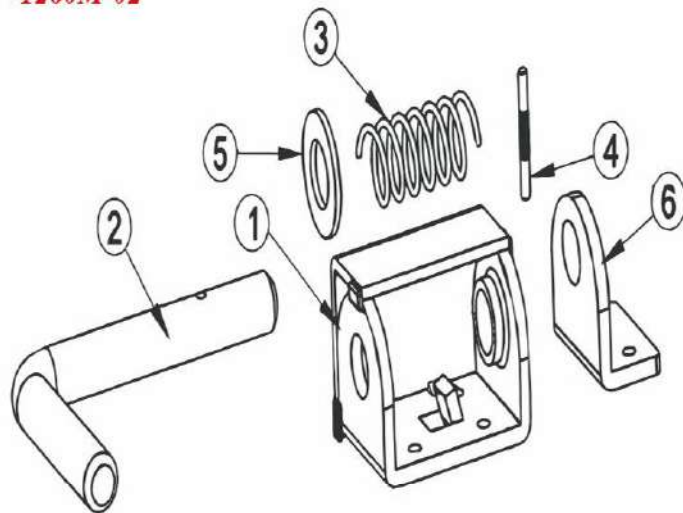

TRHDLA1260M-02

S. No.	Item Name	Material	Qty.	Finish
1	Welded Base L-Bracket	C.R.S.	1	White ZP (8µm Min.)
2	Bolt	C.D.S.	1	White ZP (8µm Min.)
3	Spring	Spring Steel	1	White ZP (8µm Min.)
4	Ø5 Knurled Pin	C.D.S.	1	White ZP (8µm Min.)
5	Washer	C.R.S.	1	White ZP (8µm Min.)
6	Keeper	C.R.S.	1	White ZP (8µm Min.)

Weight of Complete Set : 1235Kgs

Trailer Latch Assembly - Heavy Duty

1260M-03

TRHDLK1260M-03

S. No.	Item Name	Material	Qty.	Finish
1	Welded Base L-Bracket	C.R.S.	1	White ZP (8µm Min.)
2	Bolt	C.D.S.	1	White ZP (8µm Min.)
3	Spring	Spring Steel	1	White ZP (8µm Min.)
4	Ø5 Knurled Pin	C.D.S.	1	White ZP (8µm Min.)
5	Washer	C.R.S.	1	White ZP (8µm Min.)
6	Keeper	C.R.S.	1	White ZP (8µm Min.)

Weight of Complete Set : 1235Kgs

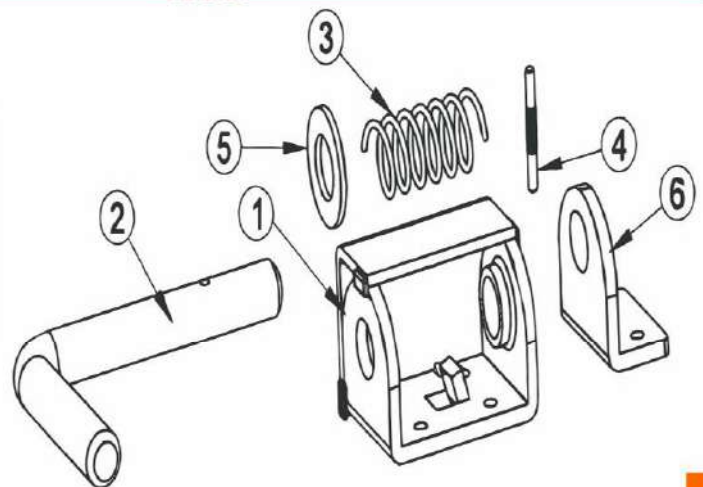



Trailer U-Bolts

Code	A	B	C	Wt.	Finish
TRUB238	11.7	76	151	0.28Kgs	Self
TRUB003	11.7	90.5	192	0.36Kgs	Self

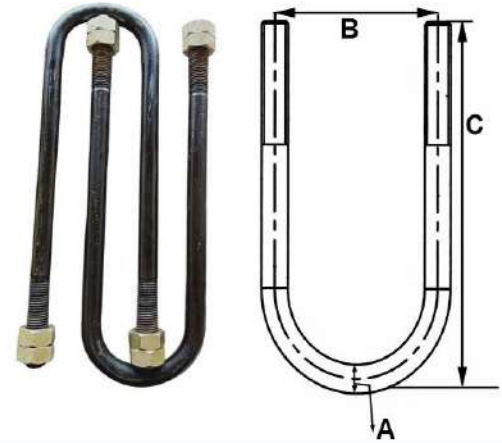

Trailer Linch Pin - With Wire

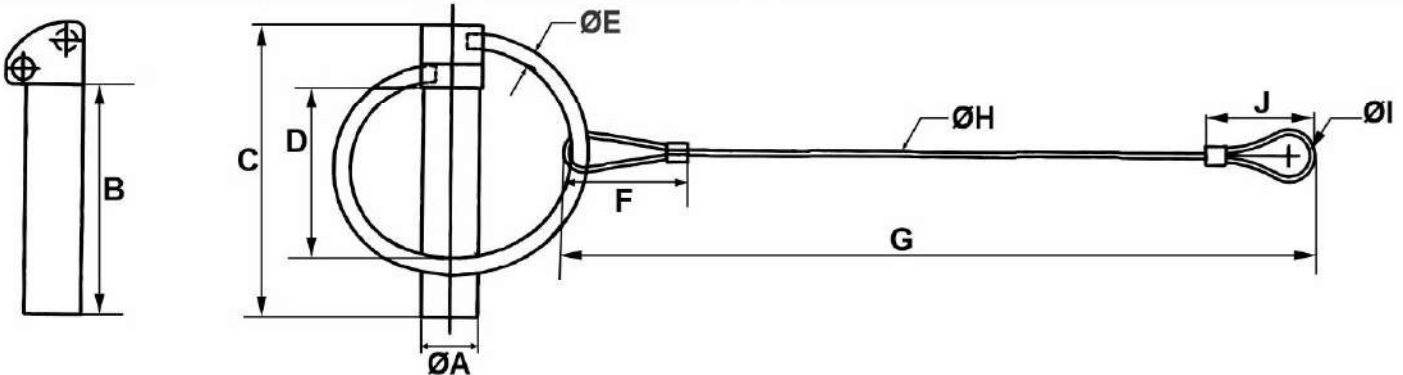

Code	ØA	B	C	D	ØE	F	G	ØH	ØI	J	Wt.
TRELP60045WC255	10	45	54	36.50	3.2	25.4	255.58	3	31.75	57.11	0.029Kgs
TRELP10045WC292.1	10	45	54	36.50	3.5	25.4	292.10	3	19.05	44.45	0.049Kgs

Trailer Linch Pin - With Clip

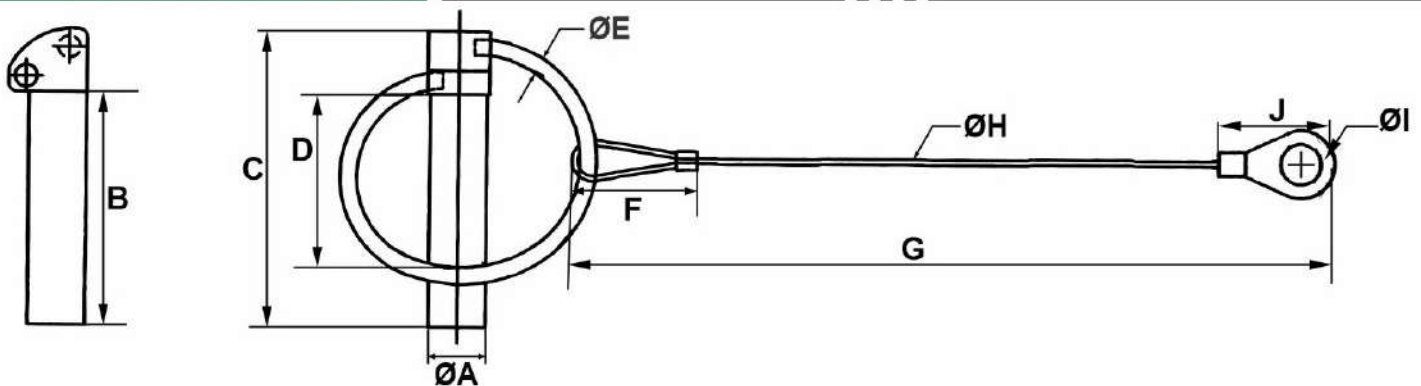

Code	ØA	B	C	D	ØE	F	G	ØH	ØI	J	Wt.
TRELP70045WC374	7	45	54	36.50	3.2	25.4	374.65	3	6.35	12.7	0.033Kgs
TRELP80045WC374	8	45	54	36.50	3.2	25.4	374.65	3	6.35	12.7	0.037Kgs
TRELP10045WC292	10	45	54	36.50	3.5	25.4	292.10	3	6.35	12.7	0.048Kgs





Trailer Stabilizer Pin

- Stabilizer Pin with bolt & Spring Washer.
- Material : Pin- C-20, Nut & Washer : 4.8 Grade.
- Finish : Golden.
- Weight of Complete Set : 0.165Kgs

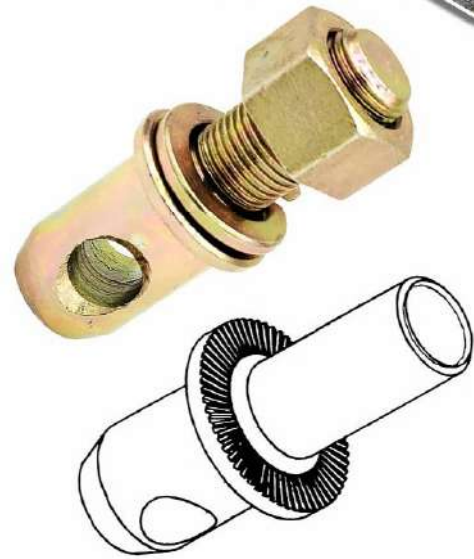

Trailer Light Boxes

Rectangular and Square Light Boxes

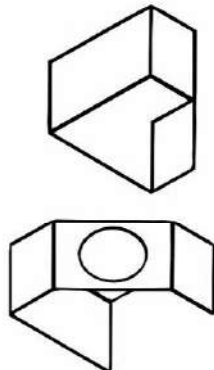
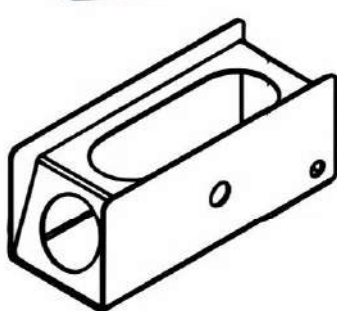

Truck Trailer Steel utility tail light boxes, weld on type heavy duty Steel box. Help to protect exterior light from element.

S. No.	Code	Shape	Side	Finish	Wt.
1	TRLT12781	Square	LH	Self	0.300Kgs
2	TRLT12782	Square	RH	Self	0.300Kgs
3	TROLB6LH	Rectangular	LH	Self	1.452Kgs
4	TROLBRH	Rectangular	RH	Self	1.350Kgs

 Oval opening for tail light and Round opening for side light.



HITCH BALLS & PINS



ITEM	HEAT TREATMENT	MATERIAL
PINS	AS PER CUSTOMER'S REQUIREMENT	EN - 8 / L.C

** HANDLE STYLE AT MANUFACTURER'S OPTION.



Let's Win... Together

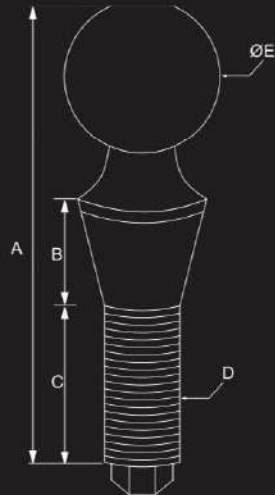

ITEM	HEAT TREATMENT	MATERIAL
BALLS	AS PER CUSTOMER'S REQUIREMENT	LOW CARBON STEEL / EN-8 / 16Mn Cr5

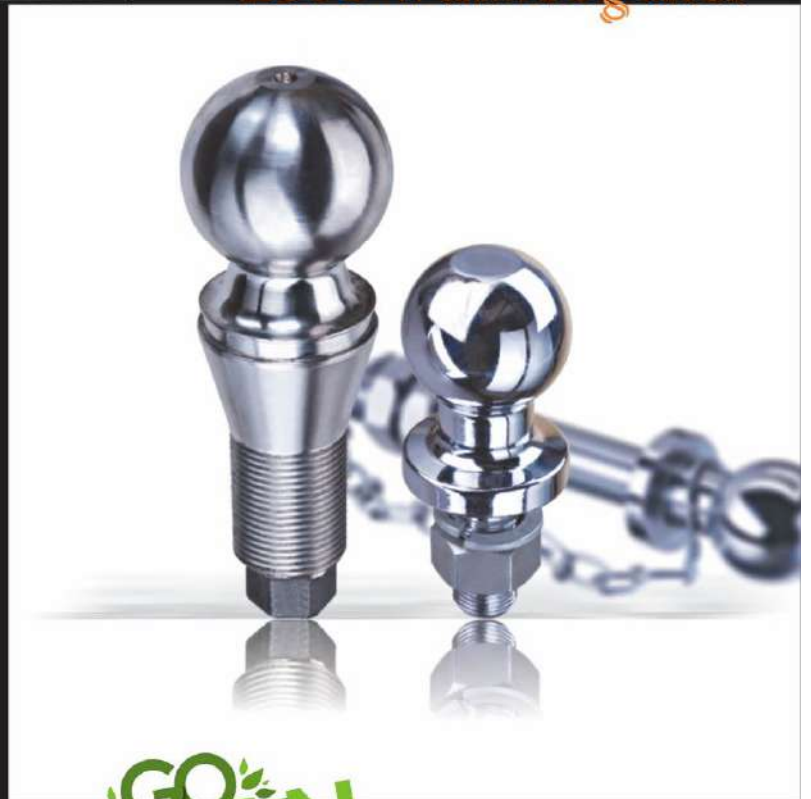

GO GREEN





Trailer Hitch Balls Attacco A Sfera

CODE	Max. Load	ØA Inch	Thread ØB Inch	Length C Inch
EHB54 - 01	2000	1-7/8	3/4	1-3/4
EHB54 - 02	3500	2	3/4	1-3/4
EHB54 - 03	5000	2	1	2-1/8
EHB54 - 04	7500	2-5/16	1-1/4	2-1/8

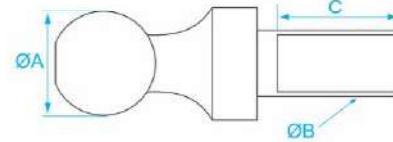

Trailer Hitch Balls Attacco A Sfera

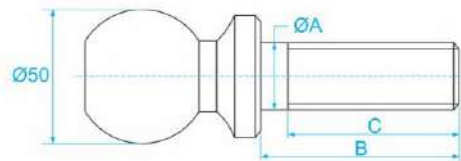

CODE	ØA	B	C
EHB54 - 08	19	70	57
EHB54 - 09	22	70	57
EHB54 - 10	25.4	70	57

Trailer Hitch Balls Attacco A Sfera

CODE	Dim. A mm	Dim. B mm	Dim. C mm	Thread D mm	ØE mm
EHB54 - 05	210.3	50.8	76.2	1.1/2-12UNF	58.73

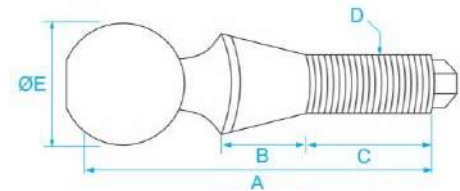

Trailer Hitch Balls Attacco A Sfera



CODE	Dim. A mm	Dim. B mm	Dim. C mm	ØD mm	Dim. E mm	Thread Size
EHB54 - 06	162	100	90	50	190	7/8"
EHB54 - 07	162	100	90	50	190	1"

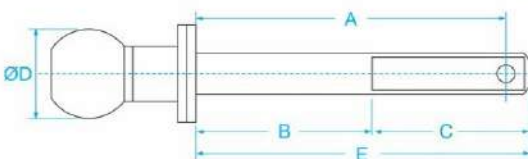



Trailer Hitch Pin with Chain & Linch Pin Spinotto D' Attacco

CODE	A	B	C	D
EHPWLP12093	12.7	92.5	6.5	127
EHPWLP12111	12.7	111	6.5	146
EHPWLP16103	15.9	103	6.5	136
EHPWLP16111	15.9	111	6.5	146
EHPWLP16165	15.9	165	6.5	200
EHPWLP19102	19	102	6.5	140
EHPWLP19110	19	110	6.5	147
EHPWLP19111	19	111	8.5	148
EHPWLP19115	19	115	12	153
EHPWLP19164	19	165	8.5	200
EHPWLP19165	19	165	6.5	204
EHPWLP19166	19	165	8.5	204
EHPWLP22115	22	115	6.5	153
EHPWLP22128	22	128	6.5	168
EHPWLP22164	22	165	6.5	200
EHPWLP22165	22	165	10	204
EHPWLP25165	25	165	10	204
EHPWLP25166	25	165	6.5	204
EHPWLP25189	25	189	12	227
EHPWLP28100	28	100	12	138
EHPWLP28120	28	120	10	158
EHPWLP28156	28	156	12	196
EHPWLP28165	28	165	6.5	204
EHPWLP28190	28	190	6.5	228
EHPWLP28189	28	189	12	228
EHPWLP30183	30	183	12	220
EHPWLP32162	32	162	6.5	204
EHPWLP32189	32	189	12	227
EHPWLP32165	32	165	10	204
EHPWLP32191	32	191	6.5	228
EHPWLP35189	35	189	12	227
EHPWLP38187	38	187	12	227

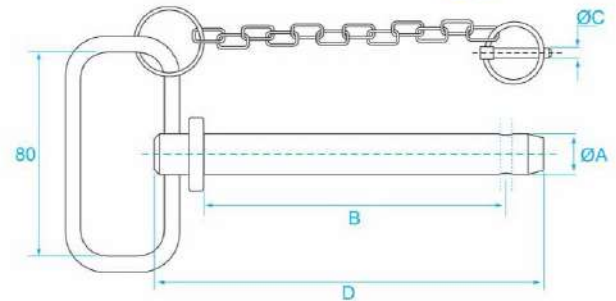

Trailer Orange Hitch Pin with Hair Pin Spinotto D' Attacco

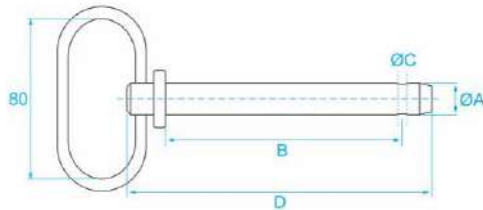
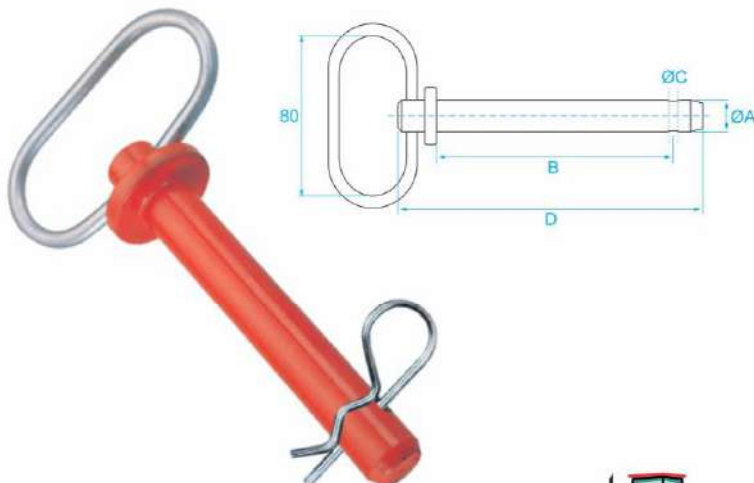

CODE	A	B	C	D
EOHP16155	16	155	4	192
EOHP19104	19	104	5	141
EOHP19162	19	162	5	199
EOHP22168	22	168	5	205
EOHP25175	25.4	175	6	212





Trailer Hitch Pin Spinotto D' Attacco

CODE	A	B	C	D
EHP12089	12.7	89	4	127
EHP12102	12.7	102	4	136
EHP12108	12.7	108	5	144
EHP12114	12.7	114	5	150
EHP16089	15.9	89	5	127
EHP16102	15.9	102	5	136
EHP16108	15.9	108	5	144
EHP16114	15.9	114	5	150
EHP16127	15.9	127	6	165
EHP16152	19	152	6	192
EHP19102	19	102	8	136
EHP19108	19	108	8	144
EHP19114	19	114	8	150
EHP19127	19	127	8	165
EHP19140	19	140	8	178
EHP19152	19	152	8	190
EHP19158	22	158	8	196
EHP22108	22	108	10	144
EHP22114	22	114	10	150
EHP22127	22	127	10	165
EHP22152	22	152	10	190
EHP22158	22	158	10	198
EHP22165	22	165	10	204
EHP25108	25.4	108	10	144
EHP25114	25.4	114	10	150
EHP25152	25.4	152	10	190
EHP25158	25.4	158	10	204
EHP25165	25.4	165	10	228
EHP25190	25.4	190	10	150
EHP28114	28	114	12	190
EHP28152	28	152	12	198
EHP28158	28	158	12	198
EHP28165	28	165	12	204
EHP28190	28	190	12	228
EHP32152	32	152	12	190
EHP32158	32	158	12	198
EHP32165	32	165	12	204
EHP32190	32	190	12	230
EHP35190	35	190	12	230
EHP38190	38	190	12	230

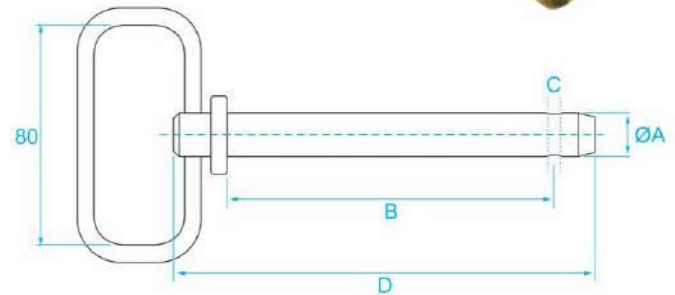

Trailer Red Handle Hitch Pin Sperni Rigidi Con Maniglian Gomma

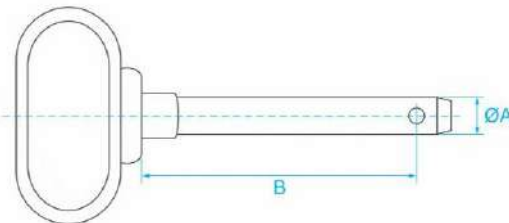

CODE	A	B
ERHHP12095	12.7	95
ERHHP16105	15.8	105
ERHHP16143	15.8	143
ERHHP19105	19	105
ERHHP19165	19	165
ERHHP22105	22	105
ERHHP22165	22.4	165
ERHHP25118	25.4	115
ERHHP25133	25.4	133
ERHHP25203	25.4	203
ERHHP28220	28.5	220
ERHHP32220	31.75	220
ERHHP38220	38.1	220





Trailer Hitch Pin with Hair Pin Spinotto D' Attacco

CODE	A	B	C	D
EHPWRP12090	12.7	90	4	125
EHPWRP12105	12.7	105	3	142
EHPWRP12110	12.7	110	4	147
EHPWRP16105	15.9	105	4	136
EHPWRP16149	15.9	149	3.5	186
EHPWRP16162	16	162	4	199
EHPWRP19098	19	98	4.5	130
EHPWRP19110	19	110	4.5	147
EHPWRP19157	19	157	4.5	194
EHPWRP19162	19	162	4.5	199
EHPWRP22110	22	110	5	147
EHPWRP22157	22	157	5	194
EHPWRP22162	22	162	5	199
EHPWRP25103	25	103	5	140
EHPWRP25110	25.4	110	5.5	147
EHPWRP25158	25	158	6	194
EHPWRP25162	25	162	6	199
EHPWRP25181	25	181	6	214
EHPWRP25118	25	118	6	155
EHPWRP28183	28	183	7	220
EHPWRP28162	28.6	162	6.5	199
EHPWRP32162	32	162	7	199

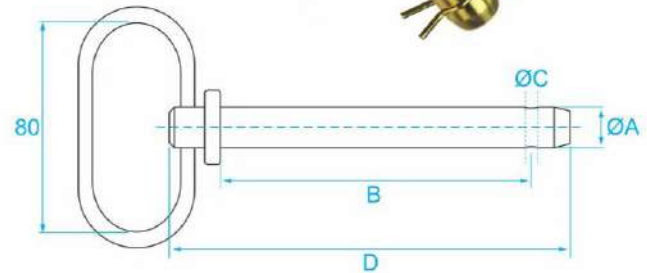

Trailer Drop Lock Pin Weld on Type

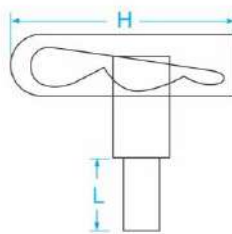

CODE	Dia. L mm	Dim. H mm
EDP - 01	13	70

Trailer Drop Lock Pin with Long Screw

CODE	Dia. L mm	Dim. H mm	Thread
EDP - 02	35	70	1/2" UNF
EDP - 03	76	70	1/2" UNF
EDP - 04	38	50	M8 x 1.25
EDP - 05	20	50	M8 x 1.25

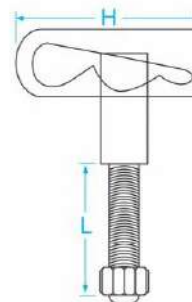

- Bright Zinc Plated.
- Complete with Nut & Washer.



Trailer Clevises (Screw Pin)

CODE	Body Dia. ØA mm	Usable Length B mm	Pin Dia. ØC mm	Thread Dia. ØD mm	Weight lbs.
ECS - 01	6.35	25.87	7.93	5/16" UNC	0.14
ECS - 02	7.93	31.75	9.52	3/8" UNC	0.22
ECS - 03	9.52	36.51	11.11	7/16" UNC	0.31
ECS - 04	11.11	42.85	12.7	1/2" UNC	0.53
ECS - 05	12.7	49.21	15.87	5/8" UNC	0.75
ECS - 06	15.87	63.5	19.05	3/4" UNC	1.1
ECS - 07	19.05	76.2	22.22	7/8" UNC	2.75
ECS - 08	22.22	82.55	25.4	1" UNC	3.58
ECS - 09	25.4	95	28.57	1-1/8" UNC	5.4
ECS - 10	28.57	107.95	31.75	1-1/4" UNC	7
ECS - 11	13.75	114.3	34.92	1-3/8" UNC	9.5

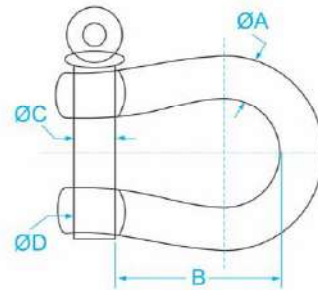

- Painted Black or any Other color as per Customer's choice.
- Yellow Zinc Plated Pin.

Trailer Clevises (Utility)

CODE	Body Dia. ØA mm	Usable Length B mm	Pin Dia. ØC mm	Weight lbs.
ECU - 01	6.35	22.22	7.93	0.1
ECU - 02	7.93	25.4	9.52	0.17
ECU - 03	9.52	31.75	11.11	0.28
ECU - 04	11.11	38.05	12.7	0.42
ECU - 05	12.7	42.86	15.87	0.66
ECU - 06	15.87	50.8	19.05	1.2

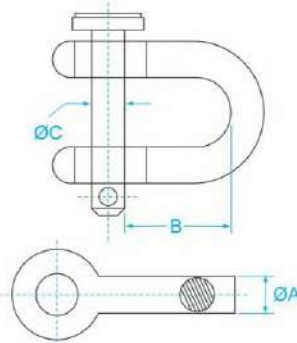

Trailer Strap Hinge

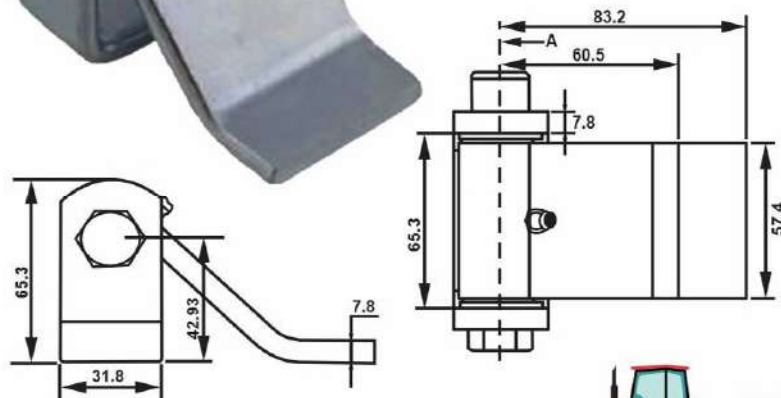

Code	Description	Washers	Finish
TRH1032LH	Left Hand	Belleville	Zinc Plated
TRH1032RH	Right Hand	Belleville	Zinc Plated
TRH1032LH-01	Left Hand	Belleville	Mill
TRH1032RH-01	Right Hand	Belleville	Mill
TRH1032LH-03	Left Hand	Flat with Bushing	Mill
TRH1032RH-03	Right Hand	Flat with Bushing	Mill

- Auto Trailer Door Hinges.
- Great for Doors on Freight Trucks, Horse Trailers & Dump Trailers.
- Heavy duty Steel, ready to be welded on.
- Weather resistant, Product can withstand harsh weather conditions.





Trailer Strap Hinge with Brass Washer

Code	Description	Washers	Finish
TRH1032LH-05	Left Hand	Flat with Bushing	Mill
TRH1032RH-05	Right Hand	Flat with Bushing	Mill

- Auto Trailer Door Hinges.
- Great for Doors on Freight Trucks, Horse Trailers & Dump Trailers.
- Heavy duty Steel, ready to be welded on.
- Weather resistant, Product can withstand harsh weather conditions.

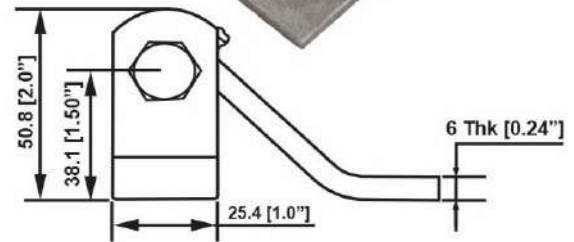
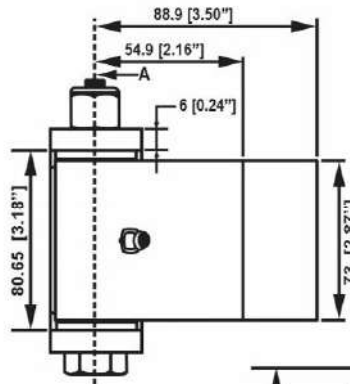

Trailer Steel Strap Hing

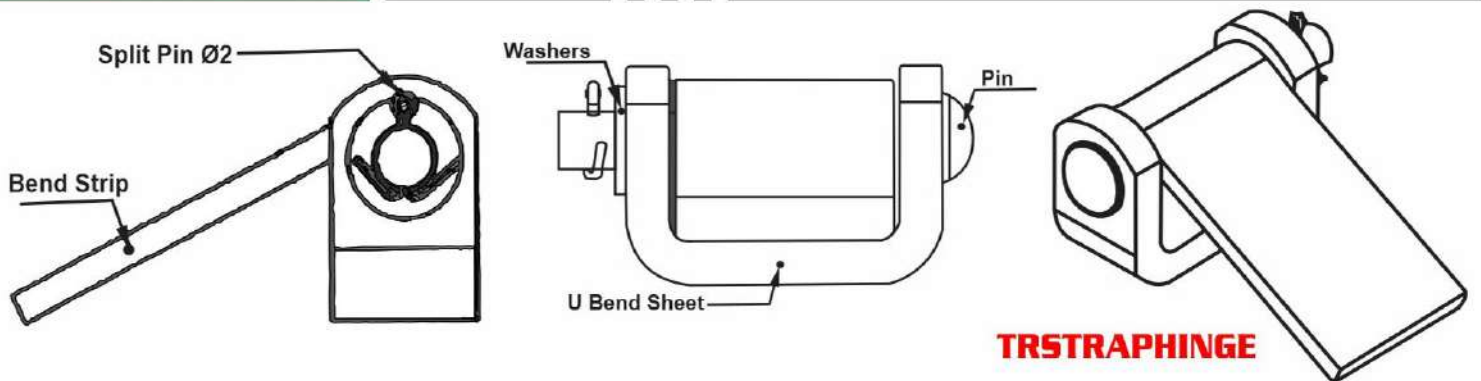

TRSTRAPHINGE

Trailer 2000 Ib Forged Steel Tie Down Ring with Weld Bracket

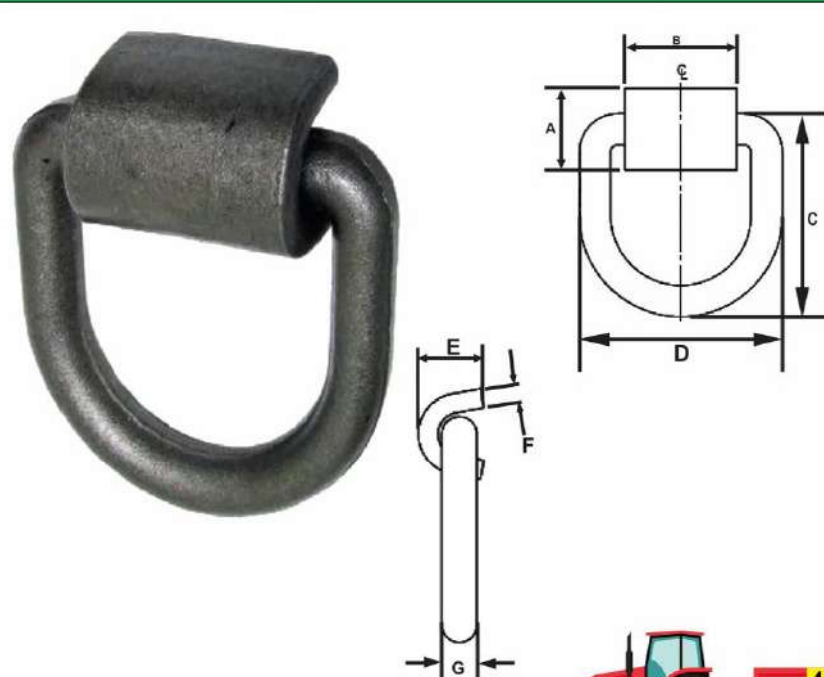

TR866-10

Scale	A	B	C	D	E	F	G
Inch	1.33	1.80	3.48	3.37	0.95	0.3	Ø0.51
MM	33.8	45.7	88.5	85.7	24.1	7.6	Ø13.0

Finish : Steel, Mill





Trailer Tilt Hinge *(Trailer Dump Body Hinge Heavy Duty, Greasable Weld on Solid Steel)*

Tilt Trailers are extremely valuable in a wide range of Construction, Agriculture and other application. There are several types of Tilt Trailer layouts. However they all rely on tilt or pivot Hinges and other key hardware to operate. **JRS** Farm parts offer numerous options to suit your unique requirements.

- We can create customer parts for you, if need our Tilt Hinges include 1/4" grease fitting for easy lubrication maintenance.
- For application on dump trailers, dump trucks or dump bodies unfinished for easy welding and painting.
- Removable hardware for easy assembly.
- Made from high-quality material for ultimate durability and long Service life.
- Strict Quality control standards to build and test.

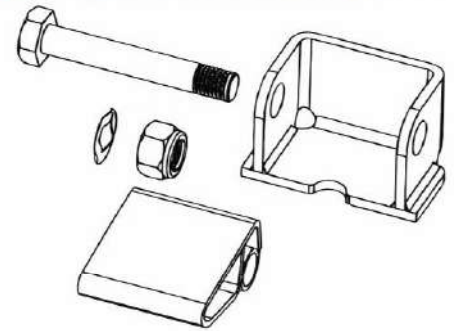

Code	Description	Finish	Weight
TRH3032	Steel Tilt Hinge, 8mm long, Steel tube, Hex Screw, SS Triple-wave washer, w/grease fitting assy. (assembled)	Short Blast with Oiled	3.629Kgs
TRH3032-01	Steel Tilt Hinge, 6mm long, mill finish leaf and base, Zinc plated hex bolt, lock nut and grease fitting, SS washers.	Short Blast with Oiled	3.02Kgs

Trailer 6000 Ib Steel Tie Down Ring



TRTD890ZN
Steel, Zinc Plated

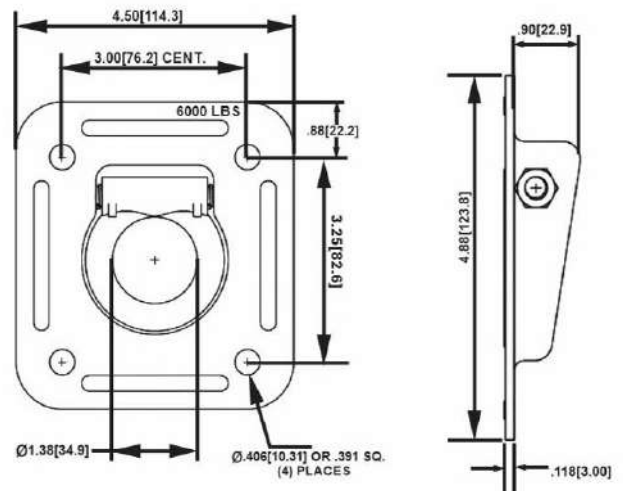



Trailer 2000lb Steel Tie Down Ring

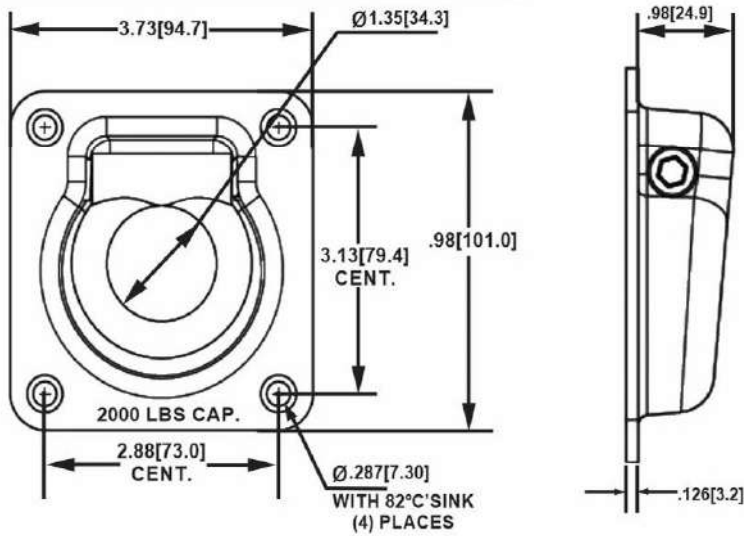

TRTD891ZN
Steel, Zinc Plated

Trailer 4000 lb Forged Steel Tie Down Ring



TREIL866
Steel, Mill

TREIL866ZN
Steel, Zinc Plated

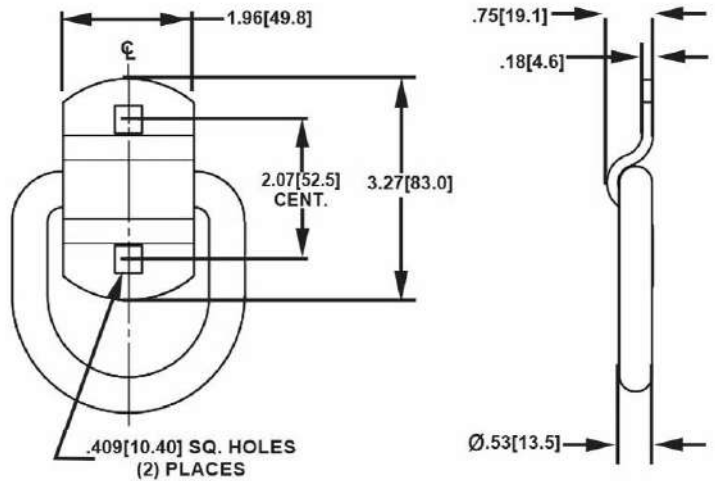

Trailer 3500 lb Forged Steel Tie Down Ring

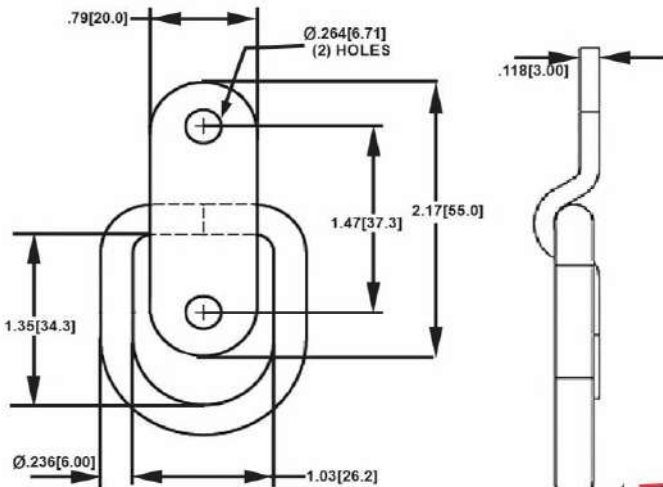

TR861
Steel, Zinc Plated



TR86155
SS304, Electroplated





Trailer Clevis Slip Hook with Latch

Sr no.	Item Code	Size of Chain(In.)	WLL (Ton)	A	B	C	D	E	F	G	H	wt. (Kgs)
1	TRCSH14	1/4"	1.4	65	24.4	20	25.4	10.4	11.5	20	12.5	0.250
2	TRCSH516	5/16"	2.5	72	26.5	22.5	30	11.7	11.5	24	16	0.380
3	TRCSH38	3/8"	4	86	29	27	36	15	11.5	28	18	0.615
4	TRCSH12	1/2"	6	101	36	44	42	19	16	34	20	1.108

Finish : Hook & Split Pin : Golden ZP
 Latch : Silver ZP
 Material : L.C.

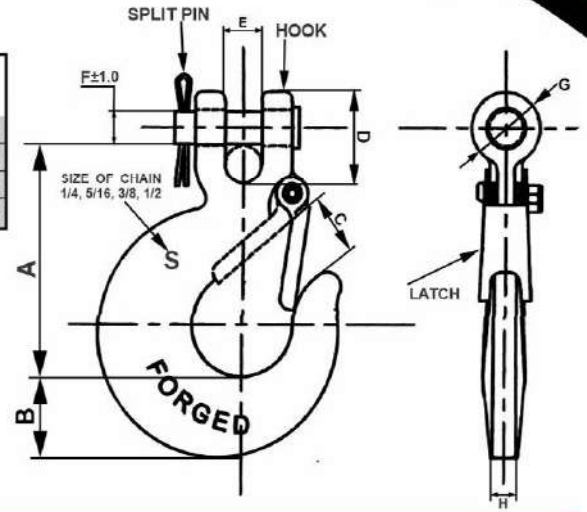

Trailer Hook with Chain

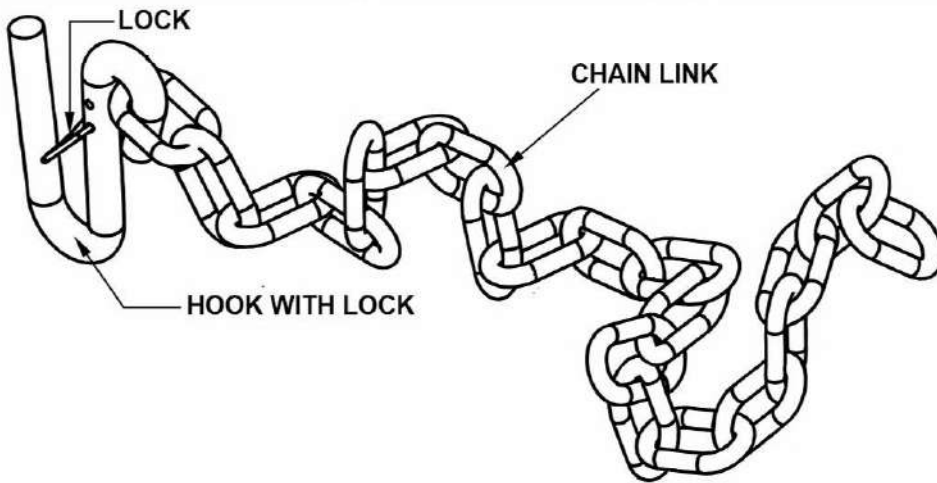

TRC1427LS

S. No.	Description	Material	Qty.
1	Ø12mm Hook	C-10/C-20	1
2	Ø2mm Lock	Spring Steel	1
3	Ø6.5mm Chain Link	C-10/C-20	20

Trailer 5/16" Grade 30 Chain 6" Long

TRMK55CC104

Material : C10/C20/EN8
 Finish : White Zinc Plated (5µm Min.)
 Weight of Complete chain : 0.184Kgs

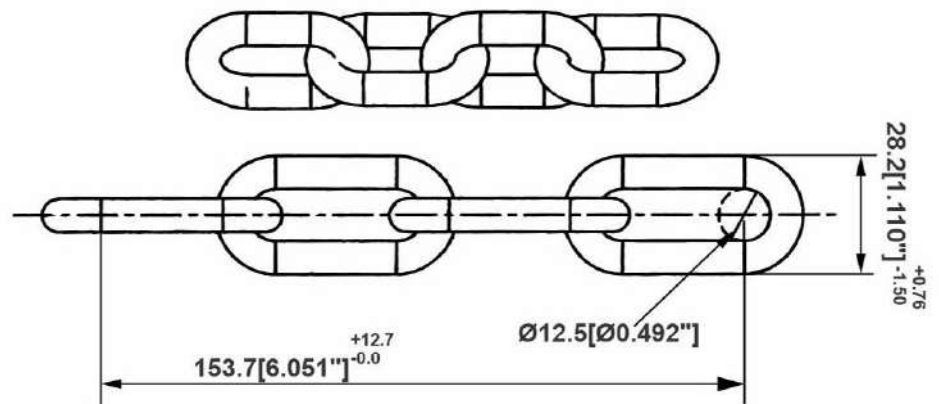



Trailer Chain 5/16"- 36" Long

Ø8[0.315"]Gr. 30 Zinc Chain X36" long

914.4[36.0"]Min.

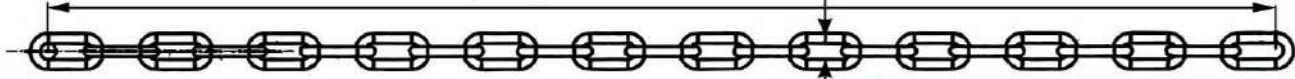

TRMK52913

Material : M.S.
 Finish : White Zinc Plated
 Weight of Complete chain : 1012Kgs

Trailer Chain 5/16"- 46" Long

Ø8[0.315"]Gr. 30 Zinc Chain X46" long

1168.4[46.0"]Min.

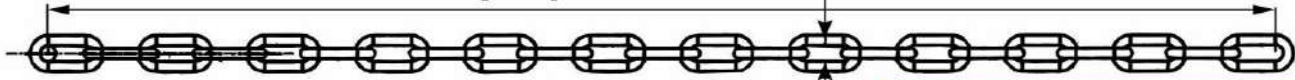

TRMK52895

Material : M.S.
 Finish : White Zinc Plated
 Weight of Complete chain : 1276Kgs

Trailer Chain 5/16"- 52.5" Long

Ø8[0.315"]Gr. 30 Zinc Chain X52.5" long

1333.5[52.5"]Min.

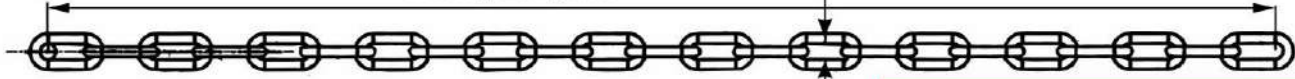

TRMK52923

Material : M.S.
 Finish : White Zinc Plated
 Weight of Complete chain : 1452Kgs

Trailer Chain 5/16"- 58" Long

Ø8[0.315"]Gr. 30 Zinc Chain X58" long

1473.4[58.0"]Min.

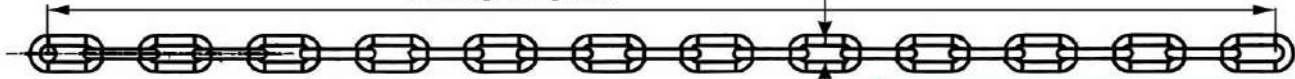

TRMK52927

Material : M.S.
 Finish : White Zinc Plated
 Weight of Complete chain : 1584Kgs





Trailer Ball Mount - Class V

- Class V Ball Mount for 2.5" receiver Tubes.
- Single Piece Forged Steel.
- Finish : Powder Coated Black.
- 1.25" Ball hole.

Part #	Rating LB GTW/TW	Length	Rise	Drop
1803405	12.0K/1.2K	10.0"	1.5"	3.0"
1803410	12.0K/1.2K	10.0"	3.5"	5.0"
1803075	20.0K/2.7K	8.5"	5.0"	2.0"
1803076	20.0K/2.7K	8.5"	2.5"	4.0"



Trailer Ball Mount - Class II



- Class V Ball Mount for 1.25" receiver Tubes.
- Single Piece Forged Steel.
- Finish : Powder Coated Black.
- 0.75" Ball hole.
- Includes 0.5" Pin & Clip.

Part #	Rating LB GTW/TW	Length	Rise	Drop
36051	3.5K/0.3K	7.0"	0.625"	1.25"
36063	3.5K/0.3K	11.75"	3.125"	N/A
36071	3.5K/0.3K	7.20"	2.625"	3.25"

Trailer Fender with Side Cover



TRFN32915

S. No.	Description	Material	Finish	Wt.
1	Fender	C10/C20	Self	3.445Kgs
2	Side Cover	C10/C20	Self	1.947Kgs

Weight of Complete Set : 5400Kgs
(Fender + Side Cover)

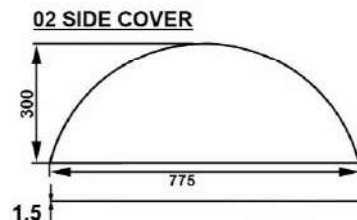
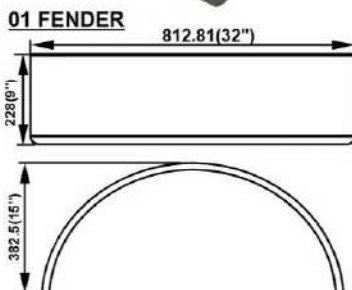



Let's Win...Together

FARM PARTS



TRAILER PARTS CATALOGUE

Eastman Industries Ltd.

Head office :

C-87, Phase-V, Focal Point, Ludhiana -141010(India)

Tel. : +91-161-2670935, 2670936, 5280000

Fax : +91-161-2670934

E-mail : info@jrsmfarmparts.com

jaswinder@jrsmfarmparts.com

Website : www.jrsmfarmparts.com

www.jrsmfarmparts.com

Eastman Cast & Forge Ltd.

Works :

Near Ludhiana Airport,

G.T. Road, Lidhiana-141120, Punjab(India)